

3 - 6 TON PACKAGED GAS/ ELECTRIC UNITS

13 SEER / UP TO 11.3 EER

80% AFUE

6-TON WITH TWO-SPEED BLOWER MOTOR AND
TWO-STAGE COMPRESSOR UP TO 15.5 IEER

COOLING CAPACITY: 34,600 — 71,000 BTU/H
HEATING CAPACITY: 36,800 — 110,400 BTU/H



■ Contents

Nomenclature.....	2
Product Specifications.....	4
Expanded Cooling Data	8
Airflow Data	18
Dimensions	24
Wiring Diagrams	28
– for Models with DDC Controls	38
Accessories	53

■ Standard Features

- Patented tubular heat exchanger
- High-efficiency scroll compressor
- High and low-pressure switches
- Copper tube / aluminum fin coils
- Contactor with lugs
- High-capacity, steel-cased filter drier
- 24-volt terminal strip
- Convertible airflow orientation
- Easy to service
- Built-in filter rack with standard 2" filters
- Bottom utility entry
- Complies with California Low NOx emissions standards
- 3-6 Tons with single speed blower motor units meet the performance specified in Table 6.8.1A of ASHRAE Standard 90.1-2010
- AHRI Certified; ETL Listed
- 6-Ton with two-speed blower motor and two-stage compressor meet the performance specified as of 1/1/2016 in Table 6.8.1-1 of ASHRAE Standard 90.1-2013

■ Cabinet Features

- Heavy-gauge, galvanized-steel cabinet with UV-resistant powder-paint finish
- Full Perimeter Rail
- Sloped drain pan



* Complete warranty details available from your local dealer or at www.daikincomfort.com.

	D	C	G	060	090	3	B	*	*	*	A	*
	1	2	3	4,5,6	7,8,9	10	11	12	13	14	15	16
	REVISION LEVELS											
	Major & Minor											
	FACTORY-INSTALLED OPTIONS											
BRAND												
D	Daikin											
CONFIGURATION												
C	Commercial											
T	High Efficiency (3-5 Tons)											
APPLICATION												
C	Cooling ³											
G	Gas Heat											
H	Heat Pump ³											
NOMINAL COOLING CAPACITY												
036	3 Tons	102	8½ Tons	300	25 Tons							
048	4 Tons	120	10 Tons									
060	5 Tons	150	12½ tons									
072	6 Tons	180	15 Tons									
090	7½ Tons	240	20 Tons									
NOMINAL HEATING CAPACITY												
Gas/Electric	A/C H/P Factory-Installed Electric Heat											
045	45,000 BTU/h	XXX	No Heat									
090	90,000 BTU/h	010	10 kW	030	30 kW							
115	115,000 BTU/h	015	15 kW	031	30 kW							
140	140,000 BTU/h	016	15 kW	045	45 kW							
210	210,000 BTU/h	018	18 kW	046	45 kW							
350	350,000 BTU/h	020	20 kW	060	60 kW							
400	400,000 BTU/h	025	25 kW									
See product specifications for heat size(s) available for each capacity.												
VOLTAGE												
1	208-230/1/60	4	460/3/60									
3	208-230/3/60	7	575/3/60									
SUPPLY FAN/DRIVE TYPE/MOTOR												
B	Belt Drive (single speed) V Two-Speed Belt Drive (also designates 6-Ton											
D	Direct Drive (3-5 Tons) with two-stage compressor)											
FACTORY-INSTALLED OPTIONS												
A	Ultra Low-Leak Downflow Economizer ¹					R Ultra Low-Leak Downflow Economizer ¹ ;						
B	DDC-BACnet protocol					DDC-BACnet protocol;						
F	Ultra Low-Leak Downflow Economizer ¹ ;					Disconnect Switch (non-fused)						
	DDC-BACnet protocol					V Low-Leak Downflow Economizer ²						
H	Disconnect Switch (non-fused)					W Low-Leak Downflow Economizer ²						
J	Ultra Low-Leak Downflow Economizer ¹ ;					Disconnect Switch (non-fused)						
	Disconnect Switch (non-fused)					X No Options						
M	Disconnect Switch (non-fused); DDC-BACnet protocol											
Note: Not all options available for all products.												
¹ Please contact RRS Rooftop Systems directly if Power Exhaust is required. Ultra Low-Leak economizer for DDC controls.												
² Please use part number DPE36722 / DPE36724 / DPE36727 if Power Exhaust is required.												
³ X= No Options in character 13th												
	FACTORY-INSTALLED OPTIONS											
X	Standard Aluminized Heat Exchanger											
S	Stainless-Steel Heat Exchanger											
D	Hinged Panels (3-12½ Tons)											
K	Stainless-Steel Heat Exchanger; Hinged Panels (3-12½ tons)											
B	Phase Monitor											
J	Stainless Steel Heat Exchanger; Phase Monitor											
M	Hinged Panel (3-12½ tons); Phase Monitor											
L	Stainless-Steel Heat Exchanger; Hinged Panels (3-12½ tons); Phase Monitor											

FACTORY-INSTALLED OPTIONS

- Stainless-Steel Heat Exchanger (DCG units only): A tubular heat exchanger made of 409-type stainless steel is installed in the unit.
- Low-Ambient Kit: Allows for cooling operation at lower outdoor temperatures. On the 3- to 6-ton units, cooling operation is extended from 60°F ambient temperature to 35°F outside air temperature. On 7½ -20 ton units, cooling operation is extended from 35°F ambient temperature to 0°F outside air temperature. For 25 ton units, cooling operation is extended from 24°F ambient temperature to 0°F outside air temperature.
- Economizers (Downflow): Based on air conditions, can provide outside air to cool the space.
- Electric Heat Kits (DCC/DTC and DCH/DTH units only): Available in all voltage options.
- Non-powered Convenience Outlet: A 120V, 15A, GFCI outlet makes it easier for technicians to service the unit once an electrician runs power to the outlet.
- Powered Convenience Outlet: A 120V, 15A, GFCI outlet powered with a transformer built into the unit. When a factory-installed powered convenience outlet is installed in the equipment, the unit MCA (Min. Circuit Ampacity) will increase by 7.5A for 208/230V units, increase by 3.75A for 460V units, and by 3A for 575V units. The MOP (Max. Overcurrent Protection) device must be sized accordingly.
- Disconnect Switch (non-fused; 3-phase units only): A disconnect switch is installed in the unit and factory wiring will be complete from the switch to the unit. Please note that for air conditioning (DCC units) and heat pump models (DCH units), the appropriate electric heat kit must be ordered to be factory-installed along with the disconnect switch (non-fused) when it is ordered. Please note that for models with a powered convenience outlet option and a disconnect switch (non-fused) option, the power to the powered convenience outlet will be shut off when the disconnect switch (non-fused) is in the off position.
- Return Air and/or Supply Air Smoke Detectors: Return air and/or supply air smoke detectors are installed in the unit.
- Hinged Access Panels: Allows access to unit's major components. Combined with latches for easy access to control box, compressor, filters and blower motor. Available on 3-12½ Tons units.
- Two-speed indoor fan blower models are available on 6, 7½, 8½, 10, 12½, 15, 20 & 25 ton units. Section 6.4.3.10.b of ASHRAE Standard 90.1-2010 and Section 6.5.3.2.1.a of ASHRAE Standard 90.1-2013 require a minimum of two fan speeds. Section 140.4(m)1 of California Energy Commission Title 24 2013 contains a similar provision. When the units with the two-speed indoor fan blowers operate on a call for the first stage of cooling, the fan operates at low speed, which is 66% of full speed. When the units operate on a call for the second stage of cooling, the fan operates at full speed. In heating operation, the fan operates at full speed. During ventilation operation, the fan operates at low speed.

	DCG036 0453D***A*	DCG036 0453B***A*	DCG036 0454B***A*	DCG036 0903D***A*	DCG036 0903B***A*	DCG036 0904B***A*	DCG036 0907B***A*
COOLING CAPACITY							
Total BTU/h	34,600	34,600	34,600	34,600	34,600	34,600	34,600
Sensible BTU/h	25,600	25,600	25,600	25,600	25,600	25,600	25,900
SEER / EER	13 / 11.0	13 / 11.0	13 / 11.0	13 / 11.0	13 / 11.0	13 / 11.0	13 / 11.0
Decibels	78	78	78	78	78	78	78
AHRI Reference #s	6345718	6345718	6345719	6345718	6345718	6345719	6345720
HEATING CAPACITY							
High Input / Output kBTU/h	46 / 36.8	46 / 36.8	46 / 36.8	92 / 74	92 / 74	92 / 74	92 / 74
Steady State Efficiency (AFUE)	80	80	80	80	80	80	80
Temperature Rise Range (°F)	25-55	25-55	25-55	40-70 / 30-60	40-70 / 30-60	40-70 / 30-60	40-70 / 30-60
No. of Burners	2	2	2	4	4	4	3
EVAPORATOR MOTOR / COIL							
Motor Type	Direct Drive	Belt Drive	Belt Drive	Direct Drive	Belt Drive	Belt Drive	Belt Drive
# of Wheels (D x W)	1 (10" x 9")	1 (11" x 10")	1 (11" x 10")	1 (11" x 10")	1 (11" x 10")	1 (11" x 10")	1 (11" x 10")
Indoor Nominal CFM	1,200	1,200	1,200	1,200	1,200	1,200	1,200
Motor Speed Tap (Cooling)	Low Speed	---	---	Low Speed	---	---	---
Indoor Motor FLA (Cooling)	2.50	3.8	1.9	2.50	3.8	1.9	1.9
Horsepower - RPM	½ - 890	1.0 - 1725	1.0 - 1725	½ - 890	1.0 - 1,725	1.0 - 1,725	1.0 - 1,725
Piston Size (Cooling)	0.072	0.072	0.072	0.068	0.068	0.068	0.068
Filter Size (")	(1) 24 x 24 x 2	(1) 24 x 24 x 2	(1) 24 x 24 x 2	(1) 24 x 24 x 2	(1) 24 x 24 x 2	(1) 24 x 24 x 2	(1) 24 x 24 x 2
Drain Size (NPT)	¾"	¾"	¾"	¾"	¾"	¾"	¾"
R-410A Refrigerant Charge Cir #1(oz.)	83	83	83	83	83	90	90
Evaporator Coil Face Area (ft²)	5.4	5.4	5.4	5.4	5.4	5.4	5.4
Rows Deep/ Fins per Inch	3/16	3/16	3/16	3 / 16	3 / 16	3 / 16	3 / 16
BELT DRIVE EVAP FAN DATA							
# of Wheels (D x W)	---	1 (11" x 10")	1 (11" x 10")	---	1 (11" x 10")	1 (11" x 10")	1 (11" x 10")
Motor Sheave	---	1VL40 X ¾	1VL40 X ¾	---	1VL40 X ¾	1VL40 X ¾	1VL40 X ¾
Blower Sheave	---	AK69 X 1	AK69 X 1	---	AK69 X 1	AK69 X 1	AK69 X 1
Belt	---	AX52	AX52	---	AX52	AX52	AX52
CONDENSER FAN / COIL							
Quantity of Condenser Fan Motors	1	1	1	1	1	1	1
Horsepower - RPM	¼ / 1,090	¼ / 1,090	¼ - 890	¼ / 1,090	¼ / 1,090	¼ - 890	¼ - 1,075
Fan Diameter / # Fan Blades	22/4	22/4	22/4	22 / 4	22 / 4	22 / 4	22 / 4
Outdoor Nominal CFM	3,800	3,800	3,800	3,800	3,800	3,800	3,800
Face Area (ft²)	17.0	17.0	17.0	18.0	18	18	13
Rows Deep/ Fins per Inch	1 / 24	1 / 24	1 / 24	1 / 22	1 / 22	1 / 22	2 / 16
COMPRESSOR							
Quantity / Stage	1 / Single	1 / Single	1 / Single	1 / Single	1 / Single	1 / Single	1 / Single
Type	Scroll	Scroll	Scroll	Scroll	Scroll	Scroll	Scroll
Compressor RLA / LRA	10.4 / 73.0	10.4 / 73.0	5.8 / 38.0	10.4 / 73.0	10.4 / 73.0	5.8 / 38.0	3.8 / 36.5
ELECTRICAL DATA							
Voltage-Phase-Frequency	208/230-3-60	208/230-3-60	460-3-60	208/230-3-60	208/230-3-60	460-3-60	575-3-60
Outdoor Fan HP / FLA	¼ / 1.4	¼ / 1.4	¼ / 0.8	¼ / 1.4	¼ / 1.4	¼ / 0.8	¼ / 0.8
Total Unit Amps	14.35	15.65	8.47	14.35	15.65	8.47	6.68
Min. Circuit Ampacity ¹	17	18	10	17	18	10	8
Max. Overcurrent Protection (amps) ²	25	25	15	25	25	15	15
Power Supply Conduit Hole / Knockout	1.125	1.125	1.125	1.125	1.125	1.125	1.125
Low-Voltage Conduit Hole	½"	½"	½"	½"	½"	½"	½"
OPERATING WEIGHT (LBS)	545	545	545	545	545	545	545
SHIP WEIGHT (LBS)	560	560	560	560	560	560	560

¹ Wire size should be determined in accordance with National Electrical Codes. Extensive wire runs will require larger wire sizes.

² May use fuses or HACR-type circuit breakers of the same size as noted.

NOTES

- Always check the S&R plate for electrical data on the unit being installed.
- When a factory-installed powered convenience outlet is installed in the equipment, the unit MCA (Min. Circuit Ampacity) will increase by 7.5A for 208/230V units, increase by 3.75A for 460V units, and by 3A for 575V units. The MOP (Max. Overcurrent Protection) device must be sized accordingly.

	DCG048 0903D***A*	DCG048 0903B***A*	DCG048 0904B***A*	DCG048 1153D***A*	DCG048 1153B***A*	DCG048 1154B***A*	DCG048 1157B***A*
COOLING CAPACITY							
Total BTU/h	45,500	45,500	45,500	45,500	45,500	45,500	45,500
Sensible BTU/h	35,000	35,000	35,000	35,000	35,000	35,000	35,000
SEER / EER	13.0 / 11.3	13.0 / 11.3	13.0 / 11.3	13.0 / 11.3	13.0 / 11.3	13.0 / 11.3	13.0 / 11.3
Decibels	78	78	78	78	78	78	78
AHRI Reference #s	6345722	6345722	6345723	6345722	6345722	6345723	6345724
Heating Capacity							
High Input /Output kBTU/h	92 / 74	92 / 74	92 / 74	115 / 92	115 / 92	115 / 92	115 / 92
Low Input /Output kBTU/h	69 / 55	69 / 55	69 / 55	86.25 / 69	86.25 / 69	86.25 / 69	86.25 / 69
Steady State Efficiency (AFUE)	80	80	80	80	80	80	80
Temperature Rise Range (°F) Hi / Low	30-60 / 15-45	30-60 / 15-45	30-60 / 15-45	40-70 / 25-55	40-70 / 25-55	40-70 / 25-55	40-70 / 25-55
No. of Burners	4	4	4	5	5	5	5
EVAPORATOR MOTOR / COIL							
Motor Type	Direct Drive	Belt Drive	Belt Drive	Direct Drive	Belt Drive	Belt Drive	Belt Drive
Indoor Nominal CFM	1,600	1,600	1,600	1,600	1,600	1,600	1,600
Motor Speed Tap (Cooling)	Medium	---	---	Medium	--	--	--
Indoor Motor FLA (Cooling)	2.87	3.8	1.9	2.87	3.8	1.9	2.3
Horsepower - RPM	½ - 1,000	1.0 / 1,725	1.0 / 1,725	½ - 1,000	1.0 / 1,725	1.0 / 1,725	1½ / 1,725
Piston Size (Cooling)	0.076	0.076	0.076	0.076	0.076	0.076	0.076
Filter Size (#)	14 x 20 x 2 (4)	14 x 20 x 2 (4)	14 x 20 x 2 (4)	14 x 20 x 2 (4)	14 x 20 x 2 (4)	14 x 20 x 2 (4)	14 x 20 x 2 (4)
Drain Size (NPT)	¾"	¾"	¾"	¾"	¾"	¾"	¾"
R-410A Refrigerant Charge (oz.)	103	105	103	103	103	103	105
Evaporator Coil Face Area (ft ²)	7.0	7.0	7.0	7.0	7.0	7.0	7.0
Rows Deep / Fins per Inch	4 / 16	4 / 16	4 / 16	4 / 16	4 / 16	4 / 16	4 / 16
BELT DRIVE EVAP FAN DATA							
# of Wheels (D" x W")	---	(1) 11 x 10	(1) 11 x 10	---	(1) 11 x 10	(1) 11 x 10	(1) 11 x 10
Motor Sheave	---	VL44 X ¾	VL44 X ¾	---	VL44 X ¾	VL44 X ¾	VL44 X ¾
Blower Sheave	---	AK66 X 1	AK66 X 1	---	AK66 X 1	AK66 X 1	AK66 X 1
Belt	---	AX52	AX52	---	AX52	AX52	AX52
CONDENSER FAN / COIL							
Quantity of Condenser Fan Motors	1	1	1	1	1	1	1
Horsepower - RPM	¼ - 1,090	¼ - 1,090	¼ - 890	¼ - 1,090	¼ - 1,090	¼ - 890	¼ - 1,075
Fan Diameter / # Fan Blades	22 / 4	22 / 4	22 / 4	22 / 4	22 / 4	22 / 4	22 / 4
Outdoor Nominal CFM	3,800	3,800	3,800	3,800	3,800	3,800	3,800
Face Area (ft ²)	17.0	17.0	17.0	17.0	17.0	17.0	17.0
Rows Deep / Fins per Inch	1 / 24	1 / 24	1 / 24	1 / 24	1 / 24	1 / 24	1 / 24
COMPRESSOR							
Quantity / Stage	1 / Single	1 / Single	1 / Single	1 / Single	1 / Single	1 / Single	1 / Single
Type	Scroll	Scroll	Scroll	Scroll	Scroll	Scroll	Scroll
Compressor RLA / LRA	13.1 / 83.1	13.1 / 83.1	6.1 / 41	13.1 / 83.1	13.1 / 83.1	6.1 / 41	4.4 / 33
ELECTRICAL DATA							
Voltage-Phase-Frequency	208/230-3-60	208/230-3-60	460-3-60	208/230-3-60	208/230-3-60	460-3-60	575-3-60
Outdoor Fan FLA	1.40	1.40	0.80	1.40	1.40	0.80	0.60
Total Unit Amps	17.4	18.3	8.8	17.4	18.3	8.8	7.3
Min. Circuit Ampacity ¹	21	22	10	21	22	10	8
Max. Overcurrent Protection (amps) ²	30	30	15	30	30	15	15
Power Supply Conduit Hole	1.125	1.125	1.125	1.125	1.125	1.125	1.125
Low-Voltage Conduit Hole	½"	½"	½"	½"	½"	½"	½"
OPERATING WEIGHT (LBS)							
	580	580	580	580	580	580	580
SHIP WEIGHT (LBS)							
	605	605	605	605	605	605	605

¹ Wire size should be determined in accordance with National Electrical Codes. Extensive wire runs will require larger wire sizes.

² May use fuses or HACR-type circuit breakers of the same size as noted.

NOTES

- Always check the S&R plate for electrical data on the unit being installed.
- When a factory-installed powered convenience outlet is installed in the equipment, the unit MCA (Min. Circuit Ampacity) will increase by 7.5A for 208/230V units, increase by 3.75A for 460V units, and by 3A for 575V units. The MOP (Max. Overcurrent Protection) device must be sized accordingly.

	DCG060 0903D***A*	DCG060 0903B***A*	DCG060 0904B***A*	DCG060 1403D***A*	DCG060 1403B***A*	DCG060 1404B***A*	DCG060 1407B***A*
COOLING CAPACITY							
Total BTU/h	58,000	58,000	58,000	58,000	58,000	58,000	58,000
Sensible BTU/h	42,800	42,800	42,800	42,800	42,800	42,800	42,800
SEER / EER	13 / 11.1	13 / 11.1	13 / 11.1	13 / 11.1	13 / 11.1	13 / 11.1	13 / 11.1
Decibels	78	78	78	78	78	78	78
ARI Reference Nos.	6345726	6345726	6345727	6345726	6345726	6345727	6345728
GAS HEATING CAPACITY							
High Input /Output kBTU/h	92 / 74	92 / 74	92 / 74	138 / 110.4	138 / 110.4	138 / 110.4	138 / 110.4
Low Input /Output kBTU/h	69 / 55	69 / 55	69 / 55	103 / 83	103 / 83	103 / 83	103 / 83
Steady State Efficiency (AFUE)	80	80	80	80	80	80	80
Temperature Rise Range (°F)	20-50 / 15-45	20-50 / 15-45	20-50 / 15-45	35-65 / 25-55	35-65 / 25-55	35-65 / 25-55	35-65 / 25-55
No. of Burners	4	4	4	6	6	6	6
EVAPORATOR MOTOR / COIL							
Motor Type	Direct	Belt	Belt	Direct	Belt	Belt	Belt
Indoor Nominal CFM	1,900	1,900	1,900	1,900	1,900	1,900	1,900
Piston Size (Cooling)	0.086	0.086	0.086	0.086	0.086	0.086	0.086
Filter Size (#)	14 x 20 x 2 (4)	14 x 20 x 2 (4)	14 x 20 x 2 (4)	14 x 20 x 2 (4)	14 x 20 x 2 (4)	14 x 20 x 2 (4)	14 x 20 x 2 (4)
Drain Size (NPT)	¾"	¾"	¾"	¾"	¾"	¾"	¾"
R-410A Refrigerant Charge (oz.)	100.8	100.8	100.8	100.8	100.8	100.8	100.8
Face Area (ft²)	7.8	7.8	7.8	7.8	7.8	7.8	7.8
Rows Deep/ Fins per Inch	4 / 16	4 / 16	4 / 16	4 / 16	4 / 16	4 / 16	4 / 16
Tube Diameter - Material	5/16 - Copper	5/16 - Copper	5/16 - Copper	5/16 - Copper	5/16 - Copper	5/16 - Copper	5/16 - Copper
BELT DRIVE EVAP FAN DATA							
# of Wheels (D x W)	---	1 (11" x 10")	1 (11" x 10")	---	1 (11" x 10")	1 (11" x 10")	1 (11" x 10")
Motor Sheave	---	VL44 X ¾	VL44 X ¾	---	VL44 X ¾	VL44 X ¾	VL44 X ¾
Blower Sheave	---	AK61 X 1	AK61 X 1	---	AK61 X 1	AK61 X 1	AK61 X 1
Belt	---	AX5	AX53	---	AX53	AX53	AX53
CONDENSER FAN / COIL							
Horsepower / RPM	¼ / 1,090	¼ / 1,090	¼ / 1,090	¼ / 1,090	¼ / 1,090	¼ / 1,090	¼ / 1,075
Fan Diameter/ # Fan Blades	22 / 4	22 / 4	22 / 4	22 / 4	22 / 4	22 / 4	22 / 1
Outdoor Nominal CFM	3,800	3,800	3,800	3,800	3,800	3,800	3,800
Face Area (ft²)	13.0	13.0	13.0	13.0	13.0	13.0	13.0
Rows Deep/ Fins per Inch	2 / 27	2 / 27	2 / 27	2 / 27	2 / 27	2 / 27	2 / 27
Tube Diameter - Material	5MM - Copper	5MM - Copper	5MM - Copper	5MM - Copper	5MM - Copper	5MM - Copper	5MM - Copper
COMPRESSOR							
Quantity / Stage	1 / Single	1 / Single	1 / Single	1 / Single	1 / Single	1 / Single	1 / Single
Type	Scroll	Scroll	Scroll	Scroll	Scroll	Scroll	Scroll
Compressor RLA / LRA	16 / 110	16 / 110	7.8 / 52	16 / 110	16 / 110	7.8 / 52	5.7 / 38.9
ELECTRICAL DATA							
Voltage-Phase-Frequency	208/230-3-60	208/230-3-60	460-3-60	208/230-3-60	208/230-3-60	460-3-60	575-3-60
Outdoor Fan HP / FLA	¼ / 1.40	¼ / 1.40	¼ / 0.8	¼ / 1.40	¼ / 1.40	¼ / 0.8	¼ / 0.6
Min. Circuit Ampacity ¹	29	25	13	29	25	12	10
Max. Overcurrent Protection ²	45 amps	40 amps	20 amps	40 amps	40 amps	20 amps	15 amps
Entrance Power Supply	1.125	1.125	1.125	1.125	1.125	1.125	1.125
Entrance Control Voltage	½"	½"	½"	½"	½"	½"	½"
OPERATING WEIGHT (LBS)							
	625	625	625	625	625	625	625
SHIP WEIGHT (LBS)							
	650	650	650	650	650	650	650

¹ Wire size should be determined in accordance with National Electrical Codes. Extensive wire runs will require larger wire sizes.

² May use fuses or HACR-type circuit breakers of the same size as noted.

NOTES

- Always check the S&R plate for electrical data on the unit being installed.
- When a factory-installed powered convenience outlet is installed in the equipment, the unit MCA (Min. Circuit Ampacity) will increase by 7.5A for 208/230V units, increase by 3.75A for 460V units, and by 3A for 575V units. The MOP (Max. Overcurrent Protection) device must be sized accordingly.

	DCG072 1403B***A*	DCG072 1403V***A*	DCG072 1404B***A*	DCG072 1404V***A*	DCG072 1407B***A*	DCG072 1407V***A*
COOLING CAPACITY						
Total BTU/h	71,000	69,000	71,000	69,000	71,000	69,000
Sensible BTU/h	49,800	51,000	49,800	51,000	49,800	51,000
EER / IEER	11.0 / 11.2	11.2/15.5	11.0 / 11.2	11.2/15.5	11.0 / 11.2	11.2/15.5
Decibels	78	78	78	78	78	78
AHRI Number	6345695	8952850	6345695	8952850	6345695	8952850
HEATING CAPACITY						
High Input / Output KBTU/h	138 / 110.4	138 / 110.4	138 / 110.4	138 / 110.4	138 / 110.4	138 / 110.4
Low Input/ Output KBTU/h	103 / 83	103 / 83	103 / 83	103 / 83	103 / 83	103 / 83
Steady State Efficiency	80	80	80	80	80	80
Temperature Rise Range (°F)	30-60 / 15-45	30-60 / 15-45	30-60 / 15-45	30-60 / 15-45	30-60 / 15-45	30-60 / 15-45
No. of Burners	6	6	6	6	6	6
EVAPORATOR MOTOR / COIL						
Motor Type	Belt Drive	2-speed Belt Drive	Belt Drive	2-speed Belt Drive	Belt Drive	2-speed Belt Drive
# of Wheels (D x W)	1 (11" x 10")	1 (11" x 10")	1 (11" x 10")	1 (11" x 10")	1 (11" x 10")	1 (11" x 10")
Indoor Nominal CFM	2,350	2,350	2,350	2,350	2,350	2,350
Indoor Motor FLA (Cooling)	5.0	6.0	2.5	2.9	2.3	2.4
Horsepower - RPM	1.5-1,725	2.0-1,725	1.5-1,725	2.0-1,725	1.5-1,725	2.0-1,725
Piston Size (Cooling)	0.094	TXV	0.094	TXV	0.094	TXV
Filter Size (Qty)	(4) 16" x 20" x 2"	(4) 16" x 20" x 2"	(4) 16" x 20" x 2"	(4) 16" x 20" x 2"	(4) 16" x 20" x 2"	(4) 16" x 20" x 2"
Drain Size (NPT)	¾"	¾"	¾"	¾"	¾"	¾"
R-410A Refrigerant Charge (oz.)	146.0	146.0	146.0	146.0	146.0	146.0
Evaporator Coil Face Area (ft²)	8.9	8.9	8.9	8.9	8.9	8.9
Rows Deep/ Fins per Inch	4/ 16	4/ 16	4/ 16	4/ 16	4/ 16	4/ 16
Motor Sheave	VL44 X 7/8	VL44 X 7/8	VL44 X 7/8	1VM50 X 7/8	VL44 X 7/8	VL44 X 7/8
Blower Sheave	AK59 X 1	AK59 X 1	AK59 X 1	AK59 X 1	AK59 X 1	AK59 X 1
Belt	AX53	AX53	AX53	AX53	AX53	AX53
CONDENSER FAN / COIL						
Quantity of Condenser Fan Motors	1	1	1	1	1	1
Horsepower - RPM	½ - 1,075	½ - 1,075	½ - 1,075	½ - 1,075	½ - 1,075	½ - 1,075
Fan Diameter / # Fan Blades	22/ 4	22/ 4	22/ 4	22/ 4	22/ 4	22/ 4
Outdoor Nominal CFM	4,200	4,200	4,200	4,200	4,200	4,200
Face Area (ft²)	19	19	19	19	19	19
Rows Deep/ Fins per Inch	2/ 27	2/ 27	2/ 27	2/ 27	2/ 27	2/ 27
COMPRESSOR						
Quantity / Stage	1 / Single	1 / Two	1 / Single	1 / Two	1 / Single	1 / Two
Type	Scroll	Scroll	Scroll	Scroll	Scroll	Scroll
Compressor RLA / LRA	19/ 123	17.6/136	9.7/ 62	8.5/66.1	7.4/ 50	6.3/55.3
ELECTRICAL DATA						
Voltage/ Phase/ Frequency	208-230/ 3/ 60	208-230/ 3/ 60	460/ 3/ 60	460/ 3/ 60	575/ 3/ 60	575/ 3/ 60
Outdoor Fan FLA	1.90	2.00	1.20	0.90	0.90	0.70
Total Unit Amps	25.9	25.6	13.4	12.3	10.6	9.4
Min. Circuit Ampacity ¹	31	30	16	14.4	12	11.0
Max. Overcurrent Protection ²	45 amps	45 amps	25 amps	20 amps	15 amps	15 amps
Entrance Power Supply	1.125"	1.125"	1.125"	1.125"	1.125"	1.125"
Entrance Control Voltage	½"	½"	½"	½"	½"	½"
OPERATING WEIGHT (LBS)						
	690	690	690	690	690	690
SHIP WEIGHT (LBS)						
	715	715	715	715	715	715

¹ Wire size should be determined in accordance with National Electrical Codes. Extensive wire runs will require larger wire sizes.

² May use fuses or HACR-type circuit breakers of the same size as noted.

NOTES

- Always check the S&R plate for electrical data on the unit being installed.
- When a factory-installed powered convenience outlet is installed in the equipment, the unit MCA (Min. Circuit Ampacity) will increase by 7.5A for 208/230V units, increase by 3.75A for 460V units, and by 3A for 575V units. The MOP (Max. Overcurrent Protection) device must be sized accordingly.

IDB		OUTDOOR AMBIENT TEMPERATURE												ENTERING INDOOR WET BULB TEMPERATURE												
		65				75				85				95				105				115				
		59	63	67	71	59	63	67	71	59	63	67	71	59	63	67	71	59	63	67	71	59	63	67	71	
70	1350	MBh	33.9	35.1	38.5	-	33.1	34.3	37.6	-	32.3	33.5	36.7	-	31.5	32.7	35.8	-	30.0	31.1	34.0	-	27.8	28.8	31.5	-
		S/T	0.72	0.60	0.42	-	0.75	0.63	0.43	-	0.77	0.64	0.44	-	0.79	0.66	0.46	-	0.82	0.69	0.48	-	0.83	0.69	0.48	-
		ΔT	17	14	11	-	17	15	11	-	17	15	11	-	17	15	11	-	17	15	11	-	16	14	10	-
		kW	2.44	2.48	2.56	-	2.61	2.66	2.74	-	2.76	2.82	2.90	-	2.90	2.95	3.05	-	3.01	3.07	3.17	-	3.11	3.17	3.27	-
		Amps	8.5	8.7	8.9	-	9.0	9.2	9.4	-	9.6	9.8	10.0	-	10.1	10.3	10.5	-	10.6	10.8	11.0	-	11.1	11.3	11.6	-
		HI PR	221	237	251	-	247	266	281	-	281	303	320	-	321	345	364	-	361	388	410	-	398	429	453	-
		LO PR	107	114	124	-	113	120	131	-	118	125	137	-	124	131	144	-	130	138	150	-	134	143	156	-
		MBh	32.9	34.1	37.4	-	32.2	33.3	36.5	-	31.4	32.5	35.6	-	30.6	31.7	34.8	-	29.1	30.2	33.0	-	26.9	27.9	30.6	-
		S/T	0.69	0.58	0.40	-	0.71	0.60	0.41	-	0.73	0.61	0.42	-	0.76	0.63	0.44	-	0.79	0.66	0.45	-	0.79	0.66	0.46	-
		ΔT	17	15	11	-	18	15	12	-	18	15	12	-	18	15	12	-	18	15	11	-	16	14	11	-
	kW	2.42	2.47	2.54	-	2.59	2.64	2.72	-	2.74	2.80	2.88	-	2.87	2.93	3.02	-	2.99	3.05	3.14	-	3.08	3.15	3.25	-	
	Amps	8.5	8.6	8.8	-	8.9	9.1	9.3	-	9.5	9.7	9.9	-	10.0	10.2	10.4	-	10.5	10.7	11.0	-	11.0	11.2	11.5	-	
	HI PR	218	235	248	-	245	264	278	-	279	300	317	-	317	342	361	-	357	384	406	-	394	425	448	-	
	LO PR	106	113	123	-	112	119	130	-	116	124	135	-	122	130	142	-	128	136	149	-	133	141	154	-	
	MBh	30.4	31.5	34.5	-	29.7	30.8	33.7	-	29.0	30.0	32.9	-	28.3	29.3	32.1	-	26.9	27.8	30.5	-	24.9	25.8	28.2	-	
	S/T	0.67	0.56	0.38	-	0.69	0.58	0.40	-	0.71	0.59	0.41	-	0.73	0.61	0.42	-	0.76	0.63	0.44	-	0.76	0.64	0.44	-	
	ΔT	18	15	12	-	18	16	12	-	18	16	12	-	18	16	12	-	18	15	12	-	17	14	11	-	
	kW	2.37	2.41	2.48	-	2.53	2.58	2.66	-	2.68	2.73	2.81	-	2.81	2.86	2.95	-	2.92	2.98	3.07	-	3.01	3.07	3.17	-	
	Amps	8.3	8.4	8.6	-	8.8	8.9	9.1	-	9.3	9.5	9.7	-	9.8	10.0	10.2	-	10.3	10.5	10.7	-	10.7	10.9	11.2	-	
	HI PR	212	228	241	-	238	256	270	-	270	291	307	-	308	331	350	-	346	373	394	-	383	412	435	-	
	LO PR	103	109	120	-	109	116	126	-	113	120	131	-	119	126	138	-	124	132	144	-	129	137	149	-	
75	1350	MBh	34.5	35.5	38.4	41.2	33.7	34.7	37.5	40.3	32.9	33.8	36.6	39.3	32.1	33.0	35.7	38.4	30.5	31.4	34.0	36.4	28.2	29.1	31.5	33.8
		S/T	0.82	0.74	0.56	0.36	0.85	0.76	0.58	0.37	0.87	0.78	0.59	0.38	0.90	0.81	0.61	0.39	0.94	0.84	0.63	0.41	0.94	0.84	0.64	0.41
		ΔT	19	18	15	10	20	18	15	10	20	18	15	10	20	18	15	10	19	18	15	10	18	17	14	9
		kW	2.46	2.50	2.58	2.65	2.63	2.68	2.76	2.85	2.78	2.84	2.93	3.02	2.92	2.98	3.07	3.17	3.03	3.10	3.19	3.29	3.13	3.20	3.30	3.40
		Amps	8.6	8.7	8.9	9.2	9.1	9.2	9.5	9.7	9.6	9.8	10.1	10.4	10.1	10.3	10.6	10.9	10.6	10.8	11.1	11.5	11.1	11.4	11.7	12.0
		HI PR	223	240	253	264	250	269	284	296	284	306	323	337	324	348	368	384	364	392	414	432	402	433	457	477
		LO PR	108	115	126	134	114	122	133	141	119	126	138	147	125	133	145	154	131	139	152	162	135	144	157	167
		MBh	33.5	34.5	37.3	40.0	32.7	33.7	36.4	39.1	31.9	32.9	35.6	38.2	31.1	32.1	34.7	37.2	29.6	30.5	33.0	35.4	27.4	28.2	30.5	32.8
		S/T	0.78	0.70	0.53	0.34	0.81	0.73	0.55	0.35	0.83	0.75	0.56	0.36	0.86	0.77	0.58	0.37	0.89	0.80	0.60	0.39	0.90	0.81	0.61	0.39
		ΔT	20	19	15	10	20	19	15	11	20	19	15	11	21	19	15	11	20	19	15	11	19	17	14	10
	kW	2.44	2.49	2.56	2.63	2.61	2.66	2.74	2.82	2.76	2.82	2.90	2.99	2.90	2.96	3.05	3.14	3.01	3.07	3.17	3.27	3.11	3.17	3.27	3.38	
	Amps	8.5	8.7	8.9	9.1	9.0	9.2	9.4	9.6	9.6	9.8	10.0	10.3	10.1	10.3	10.5	10.8	10.6	10.8	11.1	11.4	11.1	11.3	11.6	11.9	
	HI PR	221	237	251	261	248	266	281	293	281	303	320	334	321	345	364	380	361	388	410	427	399	429	453	472	
	LO PR	107	114	124	133	113	120	131	140	118	125	137	146	124	131	144	153	130	138	150	160	134	143	156	166	
	MBh	30.9	31.8	34.4	37.0	30.2	31.1	33.6	36.1	29.5	30.3	32.8	35.2	28.7	29.6	32.0	34.4	27.3	28.1	30.4	32.7	25.3	26.0	28.2	30.3	
	S/T	0.76	0.68	0.51	0.33	0.78	0.70	0.53	0.34	0.80	0.72	0.54	0.35	0.83	0.74	0.56	0.36	0.86	0.77	0.58	0.37	0.87	0.78	0.59	0.38	
	ΔT	20	19	15	11	21	19	16	11	21	19	16	11	21	19	16	11	21	19	16	11	19	18	15	10	
	kW	2.38	2.43	2.50	2.57	2.55	2.60	2.68	2.76	2.70	2.75	2.84	2.92	2.83	2.89	2.97	3.07	2.94	3.00	3.09	3.19	3.03	3.10	3.19	3.30	
	Amps	8.3	8.5	8.7	8.9	8.8	9.0	9.2	9.5	9.4	9.5	9.8	10.1	9.9	10.0	10.3	10.6	10.3	10.5	10.8	11.1	10.8	11.0	11.3	11.7	
	HI PR	214	230	243	254	240	258	273	285	273	294	310	324	311	335	353	369	350	376	398	415	387	416	439	458	
	LO PR	104	111	121	129	110	117	128	136	114	121	133	141	120	128	139	148	126	134	146	155	130	138	151	161	

IDB = Entering Indoor Dry Bulb Temperature
 High and low pressures are measured at the liquid and suction service valves.
 Shaded area reflects ACCA (TVA) Rating conditions
 kW = Total system power
 Amps = outdoor unit amps (comp.+fan)

IDB		OUTDOOR AMBIENT TEMPERATURE												ENTERING INDOOR WET BULB TEMPERATURE												
		65				75				85				95				105				115				
		59	63	67	71	59	63	67	71	59	63	67	71	59	63	67	71	59	63	67	71	59	63	67	71	
70	1800	MBh	44.6	46.2	50.6	-	43.5	45.1	49.5	-	42.5	44.1	48.3	-	41.5	43.0	47.1	-	39.4	40.8	44.7	-	36.5	37.8	41.4	-
		S/T	0.74	0.62	0.43	-	0.77	0.64	0.44	-	0.79	0.66	0.45	-	0.81	0.68	0.47	-	0.84	0.70	0.49	-	0.85	0.71	0.49	-
		ΔT	17	15	11	-	17	15	11	-	17	15	11	-	17	15	11	-	17	15	11	-	16	14	10	-
		kW	3.13	3.19	3.29	-	3.36	3.43	3.53	-	3.56	3.63	3.75	-	3.74	3.82	3.94	-	3.89	3.97	4.10	-	4.02	4.10	4.23	-
		Amps	10.2	10.4	10.6	-	10.8	11.0	11.3	-	11.5	11.7	12.0	-	12.1	12.3	12.6	-	12.7	12.9	13.3	-	13.3	13.5	13.9	-
		HI PR	239	257	271	-	268	288	304	-	305	328	346	-	347	373	394	-	390	420	444	-	431	464	490	-
		LO PR	110	117	128	-	116	124	135	-	121	129	141	-	127	135	148	-	133	142	155	-	138	147	160	-
		MBh	43.3	44.9	49.2	-	42.3	43.8	48.0	-	41.3	42.8	46.9	-	40.3	41.7	45.7	-	38.3	39.6	43.4	-	35.4	36.7	40.2	-
		S/T	0.70	0.59	0.41	-	0.73	0.61	0.42	-	0.75	0.63	0.43	-	0.77	0.65	0.45	-	0.80	0.67	0.46	-	0.81	0.68	0.47	-
		ΔT	18	15	12	-	18	15	12	-	18	15	12	-	18	15	12	-	18	15	12	-	16	14	11	-
	kW	3.11	3.17	3.27	-	3.33	3.40	3.51	-	3.53	3.61	3.72	-	3.71	3.79	3.90	-	3.86	3.94	4.06	-	3.99	4.07	4.20	-	
	Amps	10.1	10.3	10.6	-	10.7	10.9	11.2	-	11.4	11.6	11.9	-	12.0	12.2	12.5	-	12.6	12.8	13.2	-	13.2	13.4	13.8	-	
	HI PR	236	254	269	-	265	285	301	-	302	325	343	-	344	370	390	-	386	416	439	-	427	460	485	-	
	LO PR	109	116	127	-	115	123	134	-	120	128	139	-	126	134	146	-	132	140	153	-	136	145	158	-	
	MBh	40.0	41.4	45.4	-	39.0	40.4	44.3	-	38.1	39.5	43.3	-	37.2	38.5	42.2	-	35.3	36.6	40.1	-	32.7	33.9	37.1	-	
	S/T	0.68	0.57	0.39	-	0.70	0.59	0.41	-	0.72	0.60	0.42	-	0.75	0.62	0.43	-	0.77	0.65	0.45	-	0.78	0.65	0.45	-	
	ΔT	18	15	12	-	18	16	12	-	18	16	12	-	18	16	12	-	18	16	12	-	17	15	11	-	
	kW	3.04	3.10	3.19	-	3.26	3.32	3.42	-	3.45	3.52	3.63	-	3.62	3.70	3.81	-	3.76	3.84	3.97	-	3.89	3.97	4.10	-	
	Amps	9.9	10.1	10.3	-	10.5	10.7	11.0	-	11.2	11.4	11.7	-	11.7	12.0	12.3	-	12.3	12.6	12.9	-	12.9	13.1	13.5	-	
	HI PR	229	247	261	-	257	277	292	-	293	315	332	-	333	359	379	-	375	403	426	-	414	446	471	-	
	LO PR	106	113	123	-	112	119	130	-	116	124	135	-	122	130	142	-	128	136	149	-	132	141	154	-	
75	1800	MBh	45.3	46.7	50.5	54.2	44.3	45.6	49.4	53.0	43.2	44.5	48.2	51.7	42.2	43.4	47.0	50.4	40.1	41.3	44.7	47.9	37.1	38.2	41.4	44.4
		S/T	0.84	0.75	0.57	0.37	0.87	0.78	0.59	0.38	0.89	0.80	0.60	0.39	0.92	0.82	0.62	0.40	0.96	0.86	0.65	0.42	0.96	0.86	0.65	0.42
		ΔT	19	18	15	10	20	18	15	10	20	18	15	10	20	18	15	10	20	18	15	10	18	17	14	10
		kW	3.16	3.22	3.32	3.42	3.39	3.46	3.56	3.67	3.59	3.66	3.78	3.90	3.77	3.85	3.97	4.09	3.92	4.00	4.13	4.26	4.05	4.14	4.27	4.41
		Amps	10.3	10.4	10.7	11.0	10.9	11.1	11.3	11.7	11.6	11.8	12.1	12.4	12.2	12.4	12.7	13.1	12.8	13.0	13.4	13.8	13.4	13.6	14.0	14.4
		HI PR	241	260	274	286	271	291	307	321	308	331	350	365	351	377	398	415	394	424	448	467	436	469	495	516
		LO PR	111	118	129	138	118	125	137	146	122	130	142	151	128	137	149	159	135	143	156	167	139	148	162	172
		MBh	44.0	45.3	49.1	52.7	43.0	44.3	47.9	51.4	42.0	43.2	46.8	50.2	41.0	42.2	45.6	49.0	38.9	40.1	43.4	46.5	36.0	37.1	40.2	43.1
		S/T	0.80	0.72	0.54	0.35	0.83	0.74	0.56	0.36	0.85	0.76	0.58	0.37	0.88	0.79	0.59	0.38	0.91	0.82	0.62	0.40	0.92	0.82	0.62	0.40
		ΔT	20	19	15	11	21	19	15	11	21	19	15	11	21	19	16	11	20	19	15	11	19	18	14	10
	kW	3.13	3.20	3.29	3.39	3.36	3.43	3.53	3.64	3.56	3.63	3.75	3.87	3.74	3.82	3.94	4.06	3.89	3.97	4.10	4.23	4.02	4.10	4.24	4.37	
	Amps	10.2	10.4	10.6	10.9	10.8	11.0	11.3	11.6	11.5	11.7	12.0	12.3	12.1	12.3	12.6	13.0	12.7	12.9	13.3	13.7	13.3	13.5	13.9	14.3	
	HI PR	239	257	271	283	268	288	304	318	305	328	346	361	347	373	394	411	390	420	444	463	431	464	490	511	
	LO PR	110	117	128	136	116	124	135	144	121	129	141	150	127	135	148	157	133	142	155	165	138	147	160	171	
	MBh	40.6	41.8	45.3	48.6	39.7	40.9	44.2	47.5	38.7	39.9	43.2	46.3	37.8	38.9	42.1	45.2	35.9	37.0	40.0	42.9	33.3	34.2	37.1	39.8	
	S/T	0.77	0.69	0.52	0.34	0.80	0.72	0.54	0.35	0.82	0.73	0.56	0.36	0.85	0.76	0.57	0.37	0.88	0.79	0.60	0.38	0.89	0.79	0.60	0.39	
	ΔT	21	19	16	11	21	19	16	11	21	19	16	11	21	19	16	11	21	19	16	11	19	18	15	10	
	kW	3.06	3.12	3.22	3.31	3.28	3.35	3.45	3.56	3.48	3.55	3.66	3.77	3.65	3.73	3.84	3.96	3.80	3.88	4.00	4.13	3.92	4.00	4.13	4.27	
	Amps	10.0	10.2	10.4	10.7	10.6	10.8	11.0	11.3	11.3	11.5	11.7	12.1	11.8	12.1	12.4	12.7	12.4	12.6	13.0	13.4	13.0	13.2	13.6	14.0	
	HI PR	232	249	263	275	260	280	295	308	296	318	336	350	337	362	383	399	379	408	430	449	418	450	475	496	
	LO PR	107	114	124	132	113	120	131	140	117	125	136	145	123	131	143	153	129	138	150	160	134	142	155	165	

IDB = Entering Indoor Dry Bulb Temperature
 High and low pressures are measured at the liquid and suction service valves.
 Shaded area reflects ACCA (TVA) Rating conditions
 kW = Total system power
 Amps = outdoor unit amps (comp.+flan)

		OUTDOOR AMBIENT TEMPERATURE												ENTERING INDOOR WET BULB TEMPERATURE											
		65				75				85				95				105				115			
IDB	AIRFLOW	59	63	67	71	59	63	67	71	59	63	67	71	59	63	67	71	59	63	67	71	59	63	67	71
80	MBh	46.1	47.2	50.4	53.9	45.1	46.1	49.2	52.6	44.0	45.0	48.0	51.4	42.9	43.9	46.9	50.1	40.8	41.7	44.5	47.6	40.8	41.7	44.5	47.6
	S/T	0.92	0.86	0.70	0.53	0.95	0.90	0.73	0.54	1.00	0.92	0.75	0.56	1.00	0.95	0.77	0.58	1.00	1.00	0.80	0.60	1.00	1.00	0.80	0.60
	ΔT	22	21	18	14	22	21	18	15	22	21	18	15	22	21	18	15	21	21	18	15	21	21	18	15
	kW	3.18	3.24	3.34	3.44	3.41	3.48	3.59	3.70	3.62	3.69	3.81	3.93	3.80	3.88	4.00	4.13	3.95	4.04	4.16	4.30	4.08	4.17	4.31	4.45
	Amps	10.3	10.5	10.8	11.1	10.9	11.1	11.4	11.7	11.7	11.9	12.2	12.5	12.3	12.5	12.8	13.2	12.9	13.1	13.5	13.9	13.5	13.7	14.1	14.5
	HI PR	244	262	277	289	273	294	311	324	311	335	353	368	354	381	402	420	398	429	453	472	440	474	500	522
	LO PR	112	120	131	139	119	126	138	147	124	131	143	153	130	138	151	160	136	145	158	168	141	150	163	174
	MBh	44.8	45.8	48.9	52.3	43.8	44.7	47.8	51.1	42.7	43.7	46.6	49.9	41.7	42.6	45.5	48.6	39.6	40.5	43.2	46.2	36.7	37.5	40.0	42.8
	S/T	0.88	0.82	0.67	0.50	0.91	0.85	0.70	0.52	0.93	0.88	0.71	0.53	0.96	0.90	0.74	0.55	1.00	0.94	0.76	0.57	1.00	0.95	0.77	0.58
	ΔT	23	22	19	15	23	22	19	15	23	22	19	15	23	22	19	15	23	22	19	15	23	22	19	15
kW	3.16	3.22	3.32	3.42	3.39	3.46	3.56	3.67	3.59	3.66	3.78	3.90	3.77	3.85	3.97	4.10	3.92	4.00	4.13	4.26	4.05	4.14	4.27	4.41	
Amps	10.3	10.4	10.7	11.0	10.9	11.1	11.3	11.7	11.6	11.8	12.1	12.4	12.2	12.4	12.7	13.1	12.8	13.0	13.4	13.8	13.4	13.6	14.0	14.4	
HI PR	241	260	274	286	271	291	308	321	308	331	350	365	351	377	398	415	394	424	448	467	436	469	495	516	
LO PR	111	118	129	138	118	125	137	146	122	130	142	151	128	137	149	159	135	143	156	167	139	148	162	172	
MBh	41.4	42.3	45.1	48.3	40.4	41.3	44.1	47.1	39.4	40.3	43.0	46.0	38.5	39.3	42.0	44.9	36.5	37.3	39.9	42.6	33.9	34.6	37.0	39.5	
S/T	0.85	0.79	0.65	0.48	0.88	0.82	0.67	0.50	0.90	0.84	0.69	0.51	0.93	0.87	0.71	0.53	0.96	0.90	0.74	0.55	0.97	0.91	0.74	0.55	
ΔT	23	22	19	15	23	22	19	16	23	22	19	16	23	22	20	16	23	22	19	15	22	21	18	14	
kW	3.09	3.15	3.24	3.34	3.31	3.38	3.48	3.59	3.50	3.58	3.69	3.80	3.68	3.76	3.87	4.00	3.83	3.91	4.03	4.16	3.95	4.04	4.17	4.30	
Amps	10.1	10.2	10.5	10.8	10.7	10.8	11.1	11.4	11.3	11.5	11.8	12.2	11.9	12.1	12.4	12.8	12.5	12.7	13.1	13.5	13.1	13.3	13.7	14.1	
HI PR	234	252	266	277	263	282	298	311	299	321	339	354	340	366	386	403	383	412	435	453	423	455	480	501	
LO PR	108	115	125	134	114	121	133	141	119	126	138	147	125	133	145	154	131	139	152	162	135	144	157	167	
85	MBh	47.0	47.9	50.1	53.5	45.9	46.7	49.0	52.2	44.8	45.6	47.8	51.0	43.7	44.5	46.6	49.7	41.5	42.3	44.3	47.3	38.4	39.2	41.0	43.8
	S/T	0.97	0.93	0.84	0.68	1.00	0.97	0.87	0.71	1.00	0.99	0.89	0.73	1.00	1.00	0.92	0.75	1.00	1.00	0.96	0.78	1.00	1.00	0.97	0.78
	ΔT	23	23	22	19	23	23	22	19	23	23	22	19	22	23	22	19	21	22	22	19	20	20	20	18
	kW	3.20	3.27	3.37	3.47	3.44	3.51	3.62	3.73	3.65	3.72	3.84	3.96	3.83	3.91	4.03	4.16	3.98	4.07	4.20	4.33	4.12	4.21	4.34	4.48
	Amps	10.4	10.6	10.8	11.1	11.0	11.2	11.5	11.8	11.7	11.9	12.3	12.6	12.3	12.6	12.9	13.3	13.0	13.2	13.6	14.0	13.6	13.8	14.2	14.6
	HI PR	246	265	280	292	276	297	314	327	314	338	357	372	358	385	406	424	402	433	457	477	444	478	505	527
	LO PR	114	121	132	141	120	128	139	148	125	133	145	154	131	139	152	162	137	146	160	170	142	151	165	176
	MBh	45.6	46.5	48.7	51.9	44.5	45.4	47.5	50.7	43.5	44.3	46.4	49.5	42.4	43.2	45.3	48.3	40.3	41.1	43.0	45.9	37.3	38.0	39.8	42.5
	S/T	0.92	0.89	0.80	0.65	0.95	0.92	0.83	0.67	0.98	0.94	0.85	0.69	1.00	0.97	0.88	0.71	1.00	1.00	0.91	0.74	1.00	1.00	0.92	0.75
	ΔT	24	24	22	19	24	24	23	20	24	24	23	20	24	24	23	20	23	24	23	20	21	22	21	18
kW	3.18	3.24	3.34	3.44	3.41	3.48	3.59	3.70	3.62	3.69	3.81	3.93	3.80	3.88	4.00	4.13	3.95	4.04	4.16	4.30	4.08	4.17	4.31	4.45	
Amps	10.3	10.5	10.8	11.1	10.9	11.1	11.4	11.7	11.7	11.9	12.2	12.5	12.3	12.5	12.8	13.2	12.9	13.1	13.5	13.9	13.5	13.7	14.1	14.5	
HI PR	244	262	277	289	273	294	311	324	311	335	353	368	354	381	402	420	398	429	453	472	440	474	500	522	
LO PR	112	120	131	139	119	126	138	147	124	131	143	153	130	138	151	160	136	145	158	168	141	150	163	174	
MBh	42.1	42.9	44.9	47.9	41.1	41.9	43.9	46.8	40.1	40.9	42.8	45.7	39.1	39.9	41.8	44.6	37.2	37.9	39.7	42.4	34.4	35.1	36.8	39.2	
S/T	0.89	0.86	0.77	0.63	0.92	0.89	0.80	0.65	0.94	0.91	0.82	0.67	0.97	0.94	0.85	0.69	1.00	0.98	0.88	0.71	1.00	0.98	0.89	0.72	
ΔT	25	24	23	20	25	24	23	20	25	24	23	20	25	25	23	20	24	24	23	20	23	23	21	19	
kW	3.11	3.17	3.26	3.36	3.33	3.40	3.50	3.61	3.53	3.61	3.72	3.83	3.71	3.78	3.90	4.03	3.86	3.94	4.06	4.19	3.98	4.07	4.20	4.34	
Amps	10.1	10.3	10.6	10.8	10.7	10.9	11.2	11.5	11.4	11.6	11.9	12.3	12.0	12.2	12.5	12.9	12.6	12.8	13.2	13.6	13.2	13.4	13.8	14.2	
HI PR	236	254	269	280	265	285	301	314	302	324	343	357	343	370	390	407	386	416	439	458	427	459	485	506	
LO PR	109	116	127	135	115	123	134	143	120	127	139	148	126	134	146	156	132	140	153	163	136	145	158	169	

IDB = Entering Indoor Dry Bulb Temperature
 High and low pressures are measured at the liquid and suction service valves.
 Shaded area reflects AHRI Rating conditions
 kW = Total system power
 Amps = outdoor unit amps (comp.+fan)

IDB		OUTDOOR AMBIENT TEMPERATURE																							
		65				75				85				95				105				115			
		AIRFLOW		59	63	67	71	59	63	67	71	59	63	67	71	59	63	67	71	59	63	67	71	59	63
70	MBh	56.8	58.9	64.5	-	55.5	57.5	63.0	-	54.2	56.2	61.5	-	52.9	54.8	60.0	-	50.2	52.1	57.0	-	46.5	48.2	52.8	-
	S/T	0.79	0.66	0.46	-	0.82	0.68	0.47	-	0.84	0.70	0.49	-	0.87	0.72	0.50	-	0.90	0.75	0.52	-	0.91	0.76	0.53	-
	ΔT	19	17	13	-	19	17	13	-	19	17	13	-	20	17	13	-	19	17	13	-	18	16	12	-
	kW	4.07	4.15	4.28	-	4.38	4.48	4.62	-	4.66	4.76	4.92	-	4.90	5.01	5.18	-	5.11	5.23	5.40	-	5.29	5.41	5.60	-
	HI PR	242	261	275	-	272	293	309	-	309	333	352	-	352	379	400	-	396	427	450	-	438	471	498	-
	LO PR	107	114	125	-	114	121	132	-	118	126	137	-	124	132	144	-	130	138	151	-	134	143	156	-
1900	MBh	55.2	57.2	62.7	-	53.9	55.9	61.2	-	52.6	54.5	59.7	-	51.3	53.2	58.3	-	48.8	50.5	55.4	-	45.2	46.8	51.3	-
	S/T	0.75	0.63	0.44	-	0.78	0.65	0.45	-	0.80	0.67	0.46	-	0.83	0.69	0.48	-	0.86	0.72	0.50	-	0.87	0.72	0.50	-
	ΔT	20	17	13	-	20	18	13	-	20	18	13	-	21	18	14	-	20	18	13	-	19	16	12	-
	kW	4.03	4.12	4.25	-	4.35	4.44	4.58	-	4.62	4.72	4.88	-	4.86	4.97	5.14	-	5.07	5.18	5.36	-	5.25	5.37	5.55	-
	HI PR	240	258	273	-	269	290	306	-	306	330	348	-	349	375	396	-	392	422	446	-	434	467	493	-
	LO PR	106	113	124	-	112	120	131	-	117	124	136	-	123	131	143	-	129	137	149	-	133	142	155	-
1650	MBh	50.9	52.8	57.8	-	49.7	51.6	56.5	-	48.6	50.3	55.1	-	47.4	49.1	53.8	-	45.0	46.7	51.1	-	41.7	43.2	47.3	-
	S/T	0.73	0.61	0.42	-	0.75	0.63	0.44	-	0.77	0.65	0.45	-	0.80	0.67	0.46	-	0.83	0.69	0.48	-	0.83	0.70	0.48	-
	ΔT	21	18	14	-	21	18	14	-	21	18	14	-	21	18	14	-	21	18	14	-	19	17	13	-
	kW	3.94	4.02	4.15	-	4.24	4.33	4.47	-	4.51	4.61	4.76	-	4.74	4.85	5.01	-	4.94	5.05	5.22	-	5.12	5.23	5.41	-
	HI PR	233	251	265	-	261	281	297	-	297	320	338	-	338	364	385	-	381	410	433	-	421	453	478	-
	LO PR	103	110	120	-	109	116	127	-	113	121	132	-	119	127	138	-	125	133	145	-	129	137	150	-
75	MBh	57.8	59.5	64.4	69.1	56.5	58.1	62.9	67.5	55.1	56.7	61.4	65.9	53.8	55.4	59.9	64.3	51.1	52.6	56.9	61.1	47.3	48.7	52.7	56.6
	S/T	0.90	0.80	0.61	0.39	0.93	0.83	0.63	0.41	0.96	0.85	0.65	0.42	0.99	0.88	0.67	0.43	1.00	0.92	0.69	0.45	1.00	0.92	0.70	0.45
	ΔT	22	20	17	12	22	21	17	12	23	21	17	12	23	21	17	12	22	21	17	12	20	19	16	11
	kW	4.10	4.19	4.32	4.46	4.42	4.51	4.66	4.81	4.70	4.80	4.96	5.13	4.95	5.06	5.22	5.40	5.16	5.27	5.45	5.64	5.34	5.46	5.64	5.84
	HI PR	245	264	278	290	275	296	312	326	313	336	355	370	356	383	404	422	400	431	455	475	442	476	503	524
	LO PR	109	116	126	134	115	122	133	142	119	127	138	147	125	133	145	155	131	140	152	162	136	144	158	168
1900	MBh	56.1	57.8	62.5	67.1	54.8	56.4	61.1	65.6	53.5	55.1	59.6	64.0	52.2	53.7	58.2	62.4	49.6	51.1	55.3	59.3	45.9	47.3	51.2	54.9
	S/T	0.86	0.77	0.58	0.37	0.89	0.79	0.60	0.39	0.91	0.81	0.62	0.40	0.94	0.84	0.64	0.41	0.98	0.87	0.66	0.43	0.98	0.88	0.67	0.43
	ΔT	23	21	18	12	24	22	18	12	24	22	18	12	24	22	18	12	23	22	18	12	22	20	17	11
	kW	4.07	4.15	4.28	4.42	4.38	4.48	4.62	4.77	4.66	4.76	4.92	5.08	4.91	5.01	5.18	5.36	5.11	5.23	5.40	5.59	5.29	5.41	5.60	5.79
	HI PR	242	261	276	287	272	293	309	322	309	333	352	367	352	379.2	400	418	396	427	451	470	438	471	498	519
	LO PR	107	114	125	133	114	121	132	140	118	126	137	146	124	132	144	153	130	138	151	161	134	143	156	166
1650	MBh	51.8	53.3	57.7	62.0	50.6	52.1	56.4	60.5	49.4	50.8	55.0	59.1	48.2	49.6	53.7	57.6	45.8	47.1	51.0	54.7	42.4	43.7	47.3	50.7
	S/T	0.83	0.74	0.56	0.36	0.86	0.77	0.58	0.37	0.88	0.79	0.59	0.38	0.91	0.81	0.61	0.39	0.94	0.84	0.64	0.41	0.95	0.85	0.64	0.41
	ΔT	24	22	18	12	24	22	18	13	24	22	18	13	24	22	18	13	24	22	18	13	22	21	17	12
	kW	3.97	4.05	4.18	4.32	4.27	4.37	4.51	4.65	4.54	4.64	4.80	4.95	4.78	4.89	5.05	5.22	4.99	5.10	5.27	5.44	5.16	5.28	5.45	5.64
	HI PR	235	253	267	279	264	284	300	313	300	323	341	356	342	368	388	405	385	414	437	456	425	457	483	504
	LO PR	104	111	121	129	110	117	128	136	114	122	133	142	120	128	140	149	126	134	146	156	130	139	151	161

IDB = Entering Indoor Dry Bulb Temperature
 High and low pressures are measured at the liquid and suction service valves.
 Shaded area reflects ACCA (TVA) Rating conditions
 kW = Total system power
 Amps = outdoor unit amps (comp.+fan)

IDB		OUTDOOR AMBIENT TEMPERATURE																																				
		65					75					85					95					105					115											
		AIRFLOW			59			63			67			71			59			63			67			71			59			63			67			71
ENTERING INDOOR WET BULB TEMPERATURE			59			63			67			71			59			63			67			71			59			63			67			71		
2150	MBh	58.8	60.1	64.2	68.7	57.5	58.7	62.7	67.1	56.1	57.3	61.2	65.5	54.7	55.9	59.7	63.9	52.0	53.1	56.8	60.7	48.2	49.2	52.6	56.2													
	S/T	1.00	0.92	0.75	0.56	1.00	0.96	0.78	0.58	1.00	1.00	0.80	0.60	1.00	1.00	0.83	0.62	1.00	1.00	0.86	0.64	1.00	1.00	0.86	0.65													
	ΔT	25	24	21	17	25	24	21	17	24	25	21	17	23	24	21	17	22	23	21	17	21	21	19	16													
	kW	4.13	4.22	4.36	4.50	4.45	4.55	4.70	4.85	4.74	4.84	5.00	5.17	4.99	5.10	5.27	5.45	5.20	5.32	5.50	5.68	5.39	5.51	5.69	5.89													
	HI PR	247	266	281	293	278	299	315	329	316	340	359	374	360	387	409	426	404	435	460	479	447	481	508	530													
80	LO PR	110	117	127	136	116	123	135	143	120	128	140	149	126	135	147	156	133	141	154	164	137	146	159	170													
	MBh	57.1	58.4	62.4	66.7	55.8	57.0	60.9	65.1	54.5	55.6	59.5	63.6	53.1	54.3	58.0	62.0	50.5	51.6	55.1	58.9	46.8	47.8	51.0	54.6													
	S/T	0.94	0.88	0.72	0.54	0.97	0.91	0.74	0.56	1.00	0.94	0.76	0.57	1.00	0.97	0.79	0.59	1.00	1.00	0.82	0.61	1.00	1.00	0.82	0.62													
	ΔT	26	25	22	17	26	25	22	18	26	25	22	18	26	25	22	18	24	25	22	17	23	23	20	16													
	kW	4.10	4.19	4.32	4.46	4.42	4.51	4.66	4.81	4.70	4.80	4.96	5.13	4.95	5.06	5.23	5.40	5.16	5.27	5.45	5.64	5.34	5.46	5.64	5.84													
1650	HI PR	245	264	278	290	275	296	312	326	313	336	355	370	356	383	405	422	400	431	455	475	442	476	503	524													
	LO PR	109	116	126	134	115	122	133	142	119	127	138	147	125	133	145	155	131	140	152	162	136	144	158	168													
	MBh	52.7	53.9	57.5	61.5	51.5	52.6	56.2	60.1	50.3	51.4	54.9	58.7	49.0	50.1	53.5	57.2	46.6	47.6	50.9	54.4	43.2	44.1	47.1	50.4													
	S/T	0.91	0.85	0.69	0.52	0.94	0.88	0.72	0.54	0.96	0.90	0.74	0.55	0.99	0.93	0.76	0.57	1.03	0.97	0.79	0.59	1.04	0.98	0.79	0.59													
	ΔT	27	26	22	18	27	26	22	18	27	26	22	18	27	26	23	18	27	26	22	18	25	24	21	17													
1650	kW	4.00	4.09	4.21	4.35	4.31	4.40	4.54	4.69	4.58	4.68	4.84	5.00	4.82	4.93	5.09	5.26	5.03	5.14	5.31	5.49	5.20	5.32	5.50	5.69													
	HI PR	238	256	270	282	267	287	303	316	303	326	344	359	345	372	392	409	388	418	441	460	429	462	488	509													
	LO PR	105	112	122	130	111	118	129	138	116	123	134	143	121	129	141	150	127	135	148	157	132	140	153	163													

IDB		OUTDOOR AMBIENT TEMPERATURE																																				
		65					75					85					95					105					115											
		AIRFLOW			59			63			67			71			59			63			67			71			59			63			67			71
ENTERING INDOOR WET BULB TEMPERATURE			59			63			67			71			59			63			67			71			59			63			67			71		
2150	MBh	59.9	61.0	63.9	68.2	58.5	59.6	62.4	66.6	57.1	58.2	60.9	65.0	55.7	56.8	59.4	63.4	52.9	53.9	56.5	60.2	49.0	49.9	52.3	55.8													
	S/T	1.00	1.00	0.90	0.7	1.00	1.00	0.93	0.8	1.00	1.00	0.96	0.8	1.00	1.00	0.99	0.8	1.00	1.00	0.98	0.8	1.00	1.00	0.98	0.8													
	ΔT	26	26	25	21	25	25	25	22	24	25	25	22	24	24	25	22	23	23	24	21	21	21	22	20.0													
	kW	4.16	4.25	4.39	4.5	4.49	4.59	4.74	4.9	4.78	4.88	5.04	5.2	5.03	5.14	5.31	5.5	5.25	5.36	5.54	5.7	5.43	5.55	5.74	5.9													
	HI PR	250	269	284	296.1	280	302	319	332.2	319	343	362	377.9	363	391	413	430.4	409	440	464	484.2	451	486	513	535.0													
85	LO PR	111	118	129	137.0	117	124	136	144.7	122	129	141	150.4	128	136	148	158.0	134	142	155	165.6	138	147	161	171.3													
	MBh	58.1	59.2	62.0	66.2	56.8	57.9	60.6	64.6	55.4	56.5	59.2	63.1	54.1	55.1	57.7	61.6	51.4	52.3	54.8	58.5	47.6	48.5	50.8	54.2													
	S/T	0.99	0.95	0.86	0.7	1.00	0.99	0.89	0.7	1.00	1.00	0.91	0.7	1.00	1.00	0.94	0.8	1.00	1.00	0.98	0.8	1.00	1.00	0.99	0.8													
	ΔT	28	27	26	22	27	28	26	23	27	27	26	23	26	27	26	23	25	25	26	22	23	23	24	21.0													
	kW	4.13	4.22	4.36	4.5	4.45	4.55	4.70	4.9	4.74	4.84	5.00	5.2	4.99	5.10	5.27	5.4	5.20	5.32	5.50	5.7	5.39	5.51	5.69	5.9													
1900	HI PR	247	266	281	293.2	278	299	315	329.0	316	340	359	374.1	360	387	409	426.1	404	435	460	479.4	447	481	508	529.7													
	LO PR	110	117	127	135.6	116	123	135	143.3	120	128	140	148.9	126	135	147	156.5	133	141	154	164.0	137	146	159	169.6													
	MBh	53.6	54.7	57.3	61.1	52.4	53.4	55.9	59.7	51.1	52.1	54.6	58.2	49.9	50.9	53.3	56.8	47.4	48.3	50.6	54.0	43.9	44.8	46.9	50.0													
	S/T	0.95	0.92	0.83	0.7	0.99	0.95	0.86	0.7	1.00	0.97	0.88	0.7	1.00	1.00	0.91	0.7	1.00	1.00	0.94	0.8	1.00	1.00	0.95	0.8													
	ΔT	28	28	26	23	29	28	27	23	28	28	27	23	28	28	27	23	26	27	27	23	24	25	25	21.5													
1650	kW	4.03	4.12	4.25	4.4	4.34	4.44	4.58	4.7	4.62	4.72	4.88	5.0	4.86	4.97	5.14	5.3	5.07	5.18	5.36	5.5	5.25	5.37	5.55	5.7													
	HI PR	240	258	273	284.4	269	290	306	319.1	306	330	348	362.9	349	375	396	413.3	392	422	446	465.0	433	466	493	513.8													
	LO PR	106	113	124	131.6	112	120	131	139.0	117	124	136	144.5	123	131	142	151.8	129	137	149	159.0	133	141	154	164.5													

IDB = Entering Indoor Dry Bulb Temperature
 High and low pressures are measured at the liquid and suction service valves.
 Shaded area reflects AHRI Rating conditions
 kW = Total system power
 Amps = outdoor unit amps (comp.+fan)

IDB		OUTDOOR AMBIENT TEMPERATURE																							
		75				85				95				105				115							
		59	63	67	71	59	63	67	71	59	63	67	71	59	63	67	71	59	63	67	71				
		ENTERING INDOOR WET BULB TEMPERATURE																							
		AIRFLOW																							
70	MBh	69.6	72.1	79.0	-	68.0	70.4	77.2	-	66.3	68.8	75.3	-	64.7	67.1	73.5	-	61.5	63.7	69.8	-	57.0	59.0	64.7	-
	S/T	0.75	0.63	0.44	-	0.78	0.65	0.45	-	0.80	0.67	0.46	-	0.83	0.69	0.48	-	0.86	0.72	0.50	-	0.86	0.72	0.50	-
	ΔT	18	16	12	-	18	16	12	-	18	16	12	-	19	16	12	-	18	16	12	-	17	15	11	-
	kW	5.10	5.20	5.35	-	5.47	5.58	5.75	-	5.79	5.91	6.09	-	6.08	6.21	6.40	-	6.32	6.46	6.66	-	6.53	6.67	6.89	-
	HI PR	235	253	267	-	263	283	299	-	299	322	340	-	341	367	388	-	384	413	436	-	424	456	482	-
	LO PR	108	115	125	-	114	121	132	-	118	126	137	-	124	132	144	-	130	138	151	-	135	143	156	-
70	MBh	67.5	70.0	76.7	-	66.0	68.4	74.9	-	64.4	66.8	73.1	-	62.8	65.1	71.4	-	59.7	61.9	67.8	-	55.3	57.3	62.8	-
	S/T	0.72	0.60	0.42	-	0.74	0.62	0.43	-	0.76	0.64	0.44	-	0.79	0.66	0.46	-	0.82	0.68	0.47	-	0.82	0.69	0.48	-
	ΔT	19	16	12	-	19	17	13	-	19	17	13	-	19	17	13	-	19	17	13	-	18	15	12	-
	kW	5.06	5.16	5.31	-	5.43	5.54	5.70	-	5.75	5.87	6.05	-	6.03	6.16	6.35	-	6.27	6.41	6.61	-	6.48	6.62	6.83	-
	HI PR	232	250	264	-	261	281	296	-	297	319	337	-	338	363	384	-	380	409	432	-	420	452	477	-
	LO PR	107	113	124	-	113	120	131	-	117	125	136	-	123	131	143	-	129	137	150	-	133	142	155	-
2050	MBh	62.3	64.6	70.8	-	60.9	63.1	69.2	-	59.4	61.6	67.5	-	58.0	60.1	65.9	-	55.1	57.1	62.6	-	51.0	52.9	58.0	-
	S/T	0.69	0.58	0.40	-	0.72	0.60	0.42	-	0.74	0.61	0.43	-	0.76	0.63	0.44	-	0.79	0.66	0.46	-	0.80	0.66	0.46	-
	ΔT	19	17	13	-	20	17	13	-	20	17	13	-	20	17	13	-	19	17	13	-	18	16	12	-
	kW	4.95	5.05	5.19	-	5.30	5.41	5.57	-	5.61	5.73	5.90	-	5.89	6.01	6.20	-	6.12	6.25	6.45	-	6.33	6.46	6.67	-
	HI PR	225	243	256	-	253	272	287	-	288	310	327	-	328	353	372	-	369	397	419	-	407	438	463	-
	LO PR	103	110	120	-	109	116	127	-	114	121	132	-	119	127	139	-	125	133	145	-	129	138	150	-

2650	MBh	70.8	72.8	78.9	84.6	69.1	71.2	77.0	82.7	67.5	69.5	75.2	80.7	65.8	67.8	73.3	78.7	62.5	64.4	69.7	74.8	57.9	59.6	64.5	69.3
	S/T	0.86	0.77	0.58	0.37	0.89	0.79	0.60	0.39	0.91	0.81	0.62	0.40	0.94	0.84	0.64	0.41	0.97	0.87	0.66	0.42	0.98	0.88	0.67	0.43
	ΔT	21	19	16	11	21	20	16	11	21	20	16	11	21	20	16	11	21	20	16	11	20	18	15	10
	kW	5.14	5.24	5.40	5.56	5.51	5.62	5.79	5.97	5.84	5.96	6.14	6.34	6.13	6.26	6.45	6.66	6.37	6.51	6.72	6.93	6.59	6.73	6.94	7.17
	HI PR	237	255	269	281	266	286	302	315	303	326	344	359	345	371	392	408	388	417	441	459	428	461	487	508
	LO PR	109	116	126	135	115	122	133	142	119	127	139	148	125	133	146	155	131	140	153	163	136	145	158	168
75	MBh	68.7	70.7	76.6	82.2	67.1	69.1	74.8	80.3	65.5	67.4	73.0	78.3	63.9	65.8	71.2	76.4	60.7	62.5	67.7	72.6	56.2	57.9	62.7	67.3
	S/T	0.82	0.73	0.55	0.36	0.85	0.76	0.57	0.37	0.87	0.78	0.59	0.38	0.90	0.80	0.61	0.39	0.93	0.83	0.63	0.40	0.94	0.84	0.63	0.41
	ΔT	22	20	17	11	22	20	17	12	22	20	17	12	22	21	17	12	22	20	17	12	21	19	16	11
	kW	5.10	5.20	5.36	5.52	5.47	5.58	5.75	5.93	5.79	5.91	6.10	6.29	6.08	6.21	6.40	6.61	6.32	6.46	6.66	6.88	6.54	6.68	6.89	7.11
	HI PR	235	253	267	278	263	283	299	312	300	322	340	355	341	367.1	388	404	384	413	436	455	424	456	482	503
	LO PR	108	115	125	133	114	121	132	141	118	126	137	146	124	132	144	154	130	138	151	161	135	143	156	167
2050	MBh	63.4	65.3	70.7	75.8	61.9	63.8	69.0	74.1	60.5	62.2	67.4	72.3	59.0	60.7	65.7	70.5	56.0	57.7	62.4	67.0	51.9	53.4	57.8	62.1
	S/T	0.79	0.70	0.53	0.34	0.82	0.73	0.55	0.36	0.84	0.75	0.57	0.36	0.86	0.77	0.58	0.38	0.90	0.80	0.61	0.39	0.90	0.81	0.61	0.39
	ΔT	22	21	17	12	23	21	17	12	23	21	17	12	23	21	17	12	23	21	17	12	21	19	16	11
	kW	4.99	5.08	5.23	5.39	5.34	5.45	5.61	5.79	5.66	5.77	5.95	6.14	5.94	6.06	6.25	6.45	6.17	6.30	6.50	6.71	6.38	6.51	6.72	6.94
	HI PR	228	245	259	270	255	275	290	303	291	313	330	344	331	356	376	392	372	401	423	441	411	443	467	488
	LO PR	104	111	121	129	110	117	128	136	115	122	133	142	120	128	140	149	126	134	147	156	131	139	152	162

IDB = Entering Indoor Dry Bulb Temperature
 High and low pressures are measured at the liquid and suction service valves.
 Shaded area reflects ACCA (TVA) Rating conditions
 kW = Total system power
 Amps = outdoor unit amps (comp.+fan)

IDB		OUTDOOR AMBIENT TEMPERATURE																													
		65					75					85					95					105					115				
		AIRFLOW			59	63	67	71	59	63	67	71	59	63	67	71	59	63	67	71	59	63	67	71	59	63	67	71			
2650	MBh	72.0	73.6	78.6	84.0	70.3	71.9	76.8	82.1	68.7	70.2	75.0	80.1	67.0	68.4	73.1	78.2	63.6	65.0	69.5	74.3	58.9	60.2	64.4	68.8						
	S/T	0.94	0.88	0.72	0.54	1.00	0.91	0.74	0.56	1.00	0.94	0.76	0.57	1.00	0.97	0.79	0.59	1.00	1.00	0.82	0.61	1.00	1.00	0.82	0.62						
	ΔT	23	22	20	16	24	23	20	16	24	23	20	16	23	23	20	16	22	23	20	16	20	21	18	15						
	kW	5.18	5.28	5.44	5.60	5.55	5.67	5.84	6.02	5.88	6.01	6.19	6.39	6.18	6.31	6.51	6.71	6.43	6.56	6.77	6.99	6.64	6.78	7.00	7.23						
	HI PR	239	258	272	284	269	289	305	318	306	329	347	362	348	375	396	413	392	421	445	464	433	466	492	513						
LO PR	110	117	128	136	116	123	135	144	121	128	140	149	127	135	147	157	133	141	154	164	137	146	160	170							
80	MBh	69.9	71.4	76.3	81.6	68.3	69.8	74.6	79.7	66.7	68.1	72.8	77.8	65.0	66.5	71.0	75.9	61.8	63.1	67.5	72.1	57.2	58.5	62.5	66.8						
	S/T	0.90	0.84	0.68	0.51	0.93	0.87	0.71	0.53	0.95	0.89	0.73	0.54	0.98	0.92	0.75	0.56	1.00	0.96	0.78	0.58	1.00	0.96	0.78	0.59						
	ΔT	24	23	20	16	25	24	21	17	25	24	21	17	25	24	21	17	24	24	21	16	22	22	19	15						
	kW	5.14	5.24	5.40	5.56	5.51	5.62	5.79	5.97	5.84	5.96	6.14	6.34	6.13	6.26	6.45	6.66	6.38	6.51	6.72	6.93	6.59	6.73	6.94	7.17						
	HI PR	237	255	269	281	266	286	302	315	303	326	344	359	345	371	392	408	388	417	441	459	428	461	487	508						
LO PR	109	116	126	135	115	122	133	142	119	127	139	148	125	133	146	155	131	140	153	163	136	145	158	168							
2050	MBh	64.5	65.9	70.4	75.3	63.0	64.4	68.8	73.6	61.5	62.9	67.2	71.8	60.0	61.3	65.5	70.1	57.0	58.3	62.3	66.6	52.8	54.0	57.7	61.6						
	S/T	0.86	0.81	0.66	0.49	0.89	0.84	0.68	0.51	0.92	0.86	0.70	0.52	0.95	0.89	0.72	0.54	0.98	0.92	0.75	0.56	0.99	0.93	0.76	0.57						
	ΔT	25	24	21	17	25	24	21	17	25	24	21	17	26	24	21	17	25	24	21	17	23	23	20	16						
	kW	5.02	5.12	5.27	5.43	5.38	5.49	5.66	5.83	5.70	5.82	6.00	6.19	5.98	6.11	6.30	6.50	6.22	6.35	6.55	6.76	6.43	6.57	6.77	6.99						
	HI PR	230	247	261	273	258	278	293	306	293	316	334	348	334	360	380	396	376	405	427	446	415	447	472	492						
LO PR	106	112	123	130	111	119	129	138	116	123	135	143	122	129	141	151	128	136	148	158	132	140	153	163							

2650	MBh	73.3	74.7	78.2	83.5	71.6	73.0	76.4	81.5	69.9	71.2	74.6	79.6	68.2	69.5	72.8	77.6	64.7	66.0	69.1	73.7	60.0	61.1	64.0	68.3
	S/T	0.98	0.95	0.86	0.7	1.00	0.98	0.89	0.7	1.00	1.00	0.91	0.7	1.00	1.00	0.94	0.8	1.00	1.00	0.98	0.8	1.00	1.00	0.98	0.8
	ΔT	25	25	23	20	25	25	24	20	24	25	24	20	24	24	24	21	22	23	23	20	21	21	22	18.9
	kW	5.21	5.32	5.48	5.6	5.59	5.71	5.88	6.1	5.93	6.05	6.24	6.4	6.23	6.36	6.56	6.8	6.48	6.62	6.83	7.0	6.69	6.84	7.06	7.3
	HI PR	242	260	275	286.7	271	292	308	321.7	309	332	351	365.8	352	378	399	416.6	395	426	449	468.7	437	470	497	517.9
LO PR	111	118	129	137.2	117	125	136	145.0	122	130	141	150.7	128	136	149	158.3	134	143	156	165.9	139	148	161	171.6	
2350	MBh	71.1	72.5	75.9	81.0	69.5	70.8	74.2	79.1	67.8	69.1	72.4	77.3	66.2	67.5	70.6	75.4	62.9	64.1	67.1	71.6	58.2	59.4	62.2	66.3
	S/T	0.94	0.91	0.82	0.7	0.97	0.94	0.85	0.7	1.00	0.96	0.87	0.7	1.00	0.99	0.90	0.7	1.00	1.00	0.93	0.8	1.00	1.00	0.94	0.8
	ΔT	26	26	24	21	26	26	25	21	26	26	25	21	26	26	25	21	25	25	24	21	23	23	23	19.8
	kW	5.18	5.28	5.44	5.6	5.55	5.67	5.84	6.0	5.88	6.01	6.19	6.4	6.18	6.31	6.51	6.7	6.43	6.56	6.77	7.0	6.64	6.78	7.00	7.2
	HI PR	239	258	272	283.8	269	289	305	318.5	306	329	347	362.2	348	375	396	412.5	392	421	445	464.1	433	466	492	512.8
LO PR	110	117	128	135.9	116	123	135	143.6	121	128	140	149.2	127	135	147	156.7	133	141	154	164.2	137	146	160	169.9	
2050	MBh	65.7	66.9	70.1	74.8	64.1	65.4	68.5	73.0	62.6	63.8	66.8	71.3	61.1	62.3	65.2	69.6	58.0	59.1	61.9	66.1	53.7	54.8	57.4	61.2
	S/T	0.91	0.87	0.79	0.6	0.94	0.91	0.82	0.7	0.96	0.93	0.84	0.7	0.99	0.96	0.86	0.7	1.00	0.99	0.90	0.7	1.00	1.00	0.91	0.7
	ΔT	27	26	25	21	27	27	25	22	27	27	25	22	27	27	25	22	26	26	25	22	24	25	23	20.2
	kW	5.06	5.16	5.31	5.5	5.42	5.53	5.70	5.9	5.75	5.87	6.05	6.2	6.03	6.16	6.35	6.6	6.27	6.41	6.61	6.8	6.48	6.62	6.83	7.1
	HI PR	232	250	264	275.3	261	280	296	308.9	296	319	337	351.3	338	363	384	400.1	380	409	432	450.2	420	452	477	497.4
LO PR	107	113	124	131.8	113	120	131	139.3	117	124	136	144.7	123	131	143	152.0	129	137	150	159.3	133	142	155	164.8	

IDB = Entering Indoor Dry Bulb Temperature
 High and low pressures are measured at the liquid and suction service valves.
 Shaded area reflects AHRI Rating conditions
 kW = Total system power
 Amps = outdoor unit amps (comp.+fan)

IDB		OUTDOOR AMBIENT TEMPERATURE																							
		75				85				95				105				115							
		59	63	67	71	59	63	67	71	59	63	67	71	59	63	67	71	59	63	67	71				
		ENTERING INDOOR WET BULB TEMPERATURE																							
		AIRFLOW																							
70	MBh	67.6	70.1	76.8	-	66.0	68.5	75.0	-	64.5	66.8	73.2	-	62.9	65.2	71.4	-	59.8	61.9	67.9	-	55.3	57.4	62.9	-
	S/T	0.72	0.60	0.42	-	0.75	0.63	0.43	-	0.77	0.64	0.44	-	0.79	0.66	0.46	-	0.82	0.69	0.48	-	0.83	0.69	0.48	-
	Delta T	18	15	12	-	18	16	12	-	18	16	12	-	18	16	12	-	18	16	12	-	17	14	11	-
	KW	4.89	4.98	5.13	-	5.23	5.34	5.50	-	5.54	5.65	5.82	-	5.81	5.93	6.11	-	6.04	6.16	6.36	-	6.24	6.37	6.57	-
	HI PR	231	248	262	-	259	279	294	-	294	317	335	-	335	361	381	-	377	406	429	-	417	449	474	-
LO PR	110	117	128	-	116	124	135	-	121	129	140	-	127	135	147	-	133	142	155	-	138	146	160	-	
70	MBh	65.6	68.0	74.5	-	64.1	66.5	72.8	-	62.6	64.9	71.1	-	61.1	63.3	69.3	-	58.0	60.1	65.9	-	53.7	55.7	61.0	-
	S/T	0.69	0.58	0.40	-	0.71	0.60	0.41	-	0.73	0.61	0.42	-	0.76	0.63	0.44	-	0.79	0.66	0.45	-	0.79	0.66	0.46	-
	Delta T	19	16	12	-	19	16	12	-	19	16	12	-	19	16	12	-	19	16	12	-	17	15	11	-
	KW	4.85	4.95	5.09	-	5.19	5.30	5.46	-	5.50	5.61	5.78	-	5.76	5.88	6.06	-	5.99	6.12	6.31	-	6.19	6.32	6.51	-
	HI PR	228	246	260	-	256	276	291	-	292	314	331	-	332	357	377	-	374	402	424	-	413	444	469	-
LO PR	109	116	127	-	115	123	134	-	120	127	139	-	126	134	146	-	132	140	153	-	136	145	158	-	
1991	MBh	62.4	64.6	70.8	-	60.9	63.1	69.2	-	59.5	61.6	67.5	-	58.0	60.1	65.9	-	55.1	57.1	62.6	-	51.1	52.9	58.0	-
	S/T	0.66	0.55	0.38	-	0.68	0.57	0.40	-	0.70	0.59	0.41	-	0.72	0.61	0.42	-	0.75	0.63	0.44	-	0.76	0.63	0.44	-
	Delta T	19	16	12	-	19	17	13	-	19	17	13	-	19	17	13	-	19	17	13	-	18	15	12	-
	KW	4.78	4.87	5.01	-	5.12	5.22	5.37	-	5.41	5.52	5.69	-	5.67	5.79	5.97	-	5.90	6.02	6.21	-	6.09	6.22	6.41	-
	HI PR	224	241	254	-	251	270	285	-	286	307	325	-	325	350	370	-	366	394	416	-	404	435	460	-
LO PR	107	114	124	-	113	120	131	-	117	125	136	-	123	131	143	-	129	137	150	-	134	142	155	-	

IDB		OUTDOOR AMBIENT TEMPERATURE																							
		75				85				95				105				115							
		59	63	67	71	59	63	67	71	59	63	67	71	59	63	67	71	59	63	67	71				
		ENTERING INDOOR WET BULB TEMPERATURE																							
		AIRFLOW																							
75	MBh	68.8	70.8	76.6	82.2	67.2	69.1	74.8	80.3	65.6	67.5	73.1	78.4	64.0	65.9	71.3	76.5	60.8	62.6	67.7	72.7	56.3	58.0	62.7	67.3
	S/T	0.82	0.74	0.56	0.36	0.85	0.76	0.58	0.37	0.87	0.78	0.59	0.38	0.90	0.81	0.61	0.39	0.94	0.84	0.63	0.41	0.94	0.84	0.64	0.41
	Delta T	21	19	16	11	21	19	16	11	21	19	16	11	21	19	16	11	21	19	16	11	19	18	15	10
	KW	4.92	5.02	5.17	5.32	5.27	5.38	5.54	5.71	5.58	5.70	5.87	6.05	5.85	5.98	6.16	6.35	6.09	6.21	6.41	6.61	6.29	6.42	6.62	6.83
	HI PR	233	251	265	276	262	281	297	310	297	320	338	353	339	365	385	402	381	410	433	452	421	453	479	499
LO PR	111	118	129	138	118	125	136	145	122	130	142	151	128	136	149	159	134	143	156	166	139	148	161	172	
75	MBh	66.8	68.7	74.4	79.8	65.2	67.1	72.7	78.0	63.7	65.5	70.9	76.1	62.1	63.9	69.2	74.3	59.0	60.7	65.7	70.6	54.6	56.3	60.9	65.4
	S/T	0.78	0.70	0.53	0.34	0.81	0.73	0.55	0.35	0.83	0.75	0.56	0.36	0.86	0.77	0.58	0.37	0.89	0.80	0.60	0.39	0.90	0.81	0.61	0.39
	Delta T	21	20	16	11	22	20	16	11	22	20	16	11	22	20	16	11	22	20	16	11	20	19	15	10
	KW	4.89	4.98	5.13	5.28	5.23	5.34	5.50	5.66	5.54	5.65	5.82	6.00	5.81	5.93	6.11	6.30	6.04	6.16	6.36	6.56	6.24	6.37	6.57	6.78
	HI PR	231	248	262	274	259	279	294	307	294	317	335	349	335	361	381	398	377	406	429	447	417	449	474	494
LO PR	110	117	128	136	116	124	135	144	121	129	140	150	127	135	148	157	133	142	155	165	138	146	160	170	
1991	MBh	63.4	65.3	70.7	75.9	61.9	63.8	69.0	74.1	60.5	62.3	67.4	72.3	59.0	60.7	65.7	70.6	56.0	57.7	62.5	67.0	51.9	53.5	57.9	62.1
	S/T	0.75	0.67	0.51	0.33	0.78	0.70	0.53	0.34	0.80	0.71	0.54	0.35	0.82	0.74	0.56	0.36	0.86	0.76	0.58	0.37	0.86	0.77	0.58	0.38
	Delta T	22	20	17	11	22	20	17	12	22	21	17	12	22	21	17	12	22	20	17	12	21	19	16	11
	KW	4.82	4.91	5.05	5.20	5.16	5.26	5.41	5.58	5.46	5.57	5.73	5.91	5.72	5.84	6.02	6.20	5.94	6.07	6.26	6.45	6.14	6.27	6.46	6.67
	AMPS	10.5	10.8	11.1	11.4	11.3	11.5	11.9	12.3	12.2	12.4	12.8	13.3	12.9	13.2	13.6	14.1	13.7	14.0	14.5	15.0	14.5	14.8	15.3	15.8
HI PR	226	243	257	268	254	273	288	301	289	311	328	342	329	354	374	390	370	398	420	438	409	440	464	484	
LO PR	108	115	125	133	114	121	132	141	118	126	138	147	124	132	145	154	130	139	151	161	135	144	157	167	

IDB = Entering Indoor Dry Bulb Temperature
 High and low pressures are measured at the liquid and suction service valves.
 LO PR
 Shaded area reflects ACCA (TVA) Rating conditions
 kW = Total system power
 Amps = outdoor unit amps (comp.+fan)

IDB	AIRFLOW	OUTDOOR AMBIENT TEMPERATURE																													
		65					75					85					95					105					115				
		59	63	67	71	75	59	63	67	71	75	59	63	67	71	75	59	63	67	71	75	59	63	67	71	75	59	63	67	71	75
80	MBh	70.0	71.5	76.4	81.7	68.4	69.8	74.6	79.8	66.7	68.2	72.8	77.9	65.1	66.5	71.1	76.0	61.8	63.2	67.5	72.2	57.3	58.5	62.5	66.9						
	S/T	0.90	0.85	0.69	0.51	0.93	0.88	0.71	0.53	0.96	0.90	0.73	0.55	1.00	0.93	0.75	0.56	1.00	0.96	0.78	0.59	1.00	0.97	0.79	0.59						
	Delta T	23	22	19	15	23	22	19	15	23	22	19	16	24	22	20	16	23	22	19	15	21	21	18	14						
	KW	4.96	5.06	5.21	5.36	5.31	5.42	5.58	5.75	5.63	5.74	5.91	6.10	5.90	6.02	6.21	6.40	6.13	6.26	6.46	6.66	6.34	6.47	6.67	6.89						
	HI PR	235	253	268	279	264	284	300	313	300	323	341	356	342	368	389	406	385	414	437	456	425	458	483	504						
	LO PR	112	120	130	139	119	126	138	147	123	131	143	153	130	138	150	160	136	144	158	168	140	149	163	174						
85	MBh	67.9	69.4	74.2	79.3	66.4	67.8	72.5	77.4	64.8	66.2	70.7	75.6	63.2	64.6	69.0	73.8	60.0	61.4	65.6	70.1	55.6	56.8	60.7	64.9						
	S/T	0.86	0.81	0.66	0.49	0.89	0.84	0.68	0.51	0.91	0.86	0.70	0.52	0.94	0.88	0.72	0.54	0.98	0.92	0.75	0.56	0.99	0.93	0.75	0.56						
	Delta T	24	23	20	16	24	23	20	16	24	23	20	16	24	23	20	16	24	23	20	16	22	22	19	15						
	KW	4.92	5.02	5.17	5.32	5.27	5.38	5.54	5.71	5.58	5.70	5.87	6.05	5.85	5.98	6.16	6.35	6.09	6.21	6.41	6.61	6.29	6.42	6.62	6.83						
	HI PR	233	251	265	276	262	281	297	310	297	320	338	353	339	365	385	402	381	410	433	452	421	453	479	499						
	LO PR	111	118	129	138	118	125	136	145	122	130	142	151	128	136	149	159	134	143	156	166	139	148	162	172						
1991	MBh	64.5	66.0	70.5	75.3	63.0	64.4	68.8	73.6	61.5	62.9	67.2	71.8	60.0	61.4	65.6	70.1	57.0	58.3	62.3	66.6	52.8	54.0	57.7	61.7						
	S/T	0.82	0.77	0.63	0.47	0.85	0.80	0.65	0.49	0.88	0.82	0.67	0.50	0.90	0.85	0.69	0.52	0.94	0.88	0.72	0.54	0.95	0.89	0.72	0.54						
	Delta T	25	24	20	16	25	24	21	17	25	24	21	17	25	24	21	17	25	24	21	16	23	22	19	15						
	KW	4.85	4.95	5.09	5.24	5.19	5.30	5.46	5.62	5.50	5.61	5.78	5.96	5.76	5.88	6.06	6.25	5.99	6.12	6.31	6.50	6.19	6.32	6.51	6.72						
	HI PR	228	246	260	271	256	276	291	304	292	314	331	346	332	357	377	394	374	402	424	443	413	444	469	489						
	LO PR	109	116	127	135	115	123	134	142	120	127	139	148	126	134	146	156	132	140	153	163	136	145	158	169						
2525	MBh	71.2	72.6	76.0	81.1	69.5	70.9	74.3	79.2	67.9	69.2	72.5	77.3	66.2	67.5	70.7	75.4	62.9	64.1	67.2	71.7	58.3	59.4	62.2	66.4						
	S/T	0.95	0.91	0.82	0.67	0.98	0.95	0.85	0.69	1.00	0.97	0.87	0.71	1.00	1.00	0.90	0.73	1.00	1.00	0.94	0.76	1.00	1.00	0.94	0.77						
	Delta T	25	24	23	20	25	24	23	20	25	24	23	20	24	25	23	20	23	23	23	20	21	22	21	19						
	KW	5.00	5.09	5.24	5.40	5.35	5.46	5.62	5.80	5.67	5.78	5.96	6.15	5.95	6.07	6.26	6.46	6.18	6.31	6.51	6.72	6.39	6.52	6.73	6.94						
	HI PR	238	256	270	282	267	287	303	316	303	327	345	360	346	372	393	410	389	418	442	461	430	462	488	509						
	LO PR	113	121	132	140	120	128	139	148	125	133	145	154	131	139	152	162	137	146	159	170	142	151	165	175						
2250	MBh	69.1	70.5	73.8	78.7	67.5	68.8	72.1	76.9	65.9	67.2	70.4	75.1	64.3	65.6	68.7	73.2	61.1	62.3	65.2	69.6	56.6	57.7	60.4	64.5						
	S/T	0.90	0.87	0.79	0.64	0.93	0.90	0.81	0.66	0.96	0.92	0.83	0.68	0.99	0.95	0.86	0.70	1.00	0.99	0.89	0.73	1.00	1.00	0.90	0.73						
	Delta T	25	25	24	20	26	25	24	21	26	25	24	21	26	26	24	21	25	25	24	21	23	24	22	19						
	KW	4.96	5.06	5.21	5.36	5.31	5.42	5.58	5.75	5.63	5.74	5.91	6.10	5.90	6.02	6.21	6.40	6.13	6.26	6.46	6.66	6.34	6.47	6.67	6.89						
	HI PR	235	253	268	279	264	284	300	313	300	323	341	356	342	368	389	406	385	414	437	456	425	458	483	504						
	LO PR	112	120	130	139	119	126	138	147	123	131	143	153	130	138	150	160	136	144	158	168	140	149	163	174						
1991	MBh	65.7	66.9	70.1	74.8	64.1	65.4	68.5	73.1	62.6	63.8	66.9	71.3	61.1	62.3	65.2	69.6	58.0	59.2	62.0	66.1	53.8	54.8	57.4	61.2						
	S/T	0.86	0.83	0.75	0.61	0.89	0.86	0.78	0.63	0.92	0.89	0.80	0.65	0.95	0.91	0.82	0.67	0.98	0.95	0.86	0.69	0.99	0.96	0.86	0.70						
	Delta T	26	26	24	21	27	26	25	21	27	26	25	21	27	26	25	22	26	26	24	21	25	24	23	20						
	KW	4.89	4.98	5.13	5.28	5.23	5.34	5.50	5.66	5.54	5.65	5.82	6.00	5.81	5.93	6.11	6.30	6.04	6.16	6.36	6.56	6.24	6.37	6.57	6.78						
	HI PR	231	248	262	273	259	279	294	307	294	317	335	349	335	361	381	397	377	406	429	447	417	449	474	494						
	LO PR	110	117	128	136	116	124	135	144	121	129	140	150	127	135	147	157	133	142	155	165	138	146	160	170						

IDB = Entering Indoor Dry Bulb Temperature
 High and low pressures are measured at the liquid and suction service valves.
 Shaded area reflects AHRI Rating conditions
 kW = Total system power
 Amps = outdoor unit amps (comp.+fan)

STANDARD BELT DRIVE — HORIZONTAL

ESP (" H ₂ O)	TURNS OPEN											
	0		1		2		3		4		5	
	CFM	BHP	CFM	BHP	CFM	BHP	CFM	BHP	CFM	BHP	CFM	BHP
0.2	---	---	---	---	---	---	---	---	1524	0.32	1340	0.25
0.4	---	---	---	---	1628	0.41	1396	0.32	1171	0.24	900	0.16
0.6	---	---	1541	0.43	1284	0.32	1024	0.23	714	0.14	---	---
0.8	1444	0.45	1193	0.33	936	0.24	---	---	---	---	---	---
1.0	1111	0.34	806	0.23	---	---	---	---	---	---	---	---
1.2	744	0.22	---	---	---	---	---	---	---	---	---	---

HIGH-STATIC BELT DRIVE — HORIZONTAL

ESP (" H ₂ O)	TURNS OPEN											
	0		1		2		3		4		5	
	CFM	BHP	CFM	BHP	CFM	BHP	CFM	BHP	CFM	BHP	CFM	BHP
0.6	---	---	---	---	---	---	---	---	1568	0.45	1266	0.32
0.8	---	---	---	---	---	---	1492	0.47	1194	0.34	922	0.23
1.0	---	---	---	---	1476	0.52	1163	0.37	856	0.24	---	---
1.2	---	---	1458	0.57	1146	0.41	802	0.25	---	---	---	---
1.4	1458	0.63	1139	0.46	782	0.30	---	---	---	---	---	---
1.6	1139	0.52	844	0.36	---	---	---	---	---	---	---	---
1.8	844	0.42	---	---	---	---	---	---	---	---	---	---

STANDARD BELT DRIVE — DOWN SHOT

ESP (" H ₂ O)	TURNS OPEN											
	0		1		2		3		4		5	
	CFM	BHP	CFM	BHP	CFM	BHP	CFM	BHP	CFM	BHP	CFM	BHP
0.2	---	---	---	---	---	---	1596	0.36	1368	0.28	1162	0.21
0.4	---	---	---	---	1468	0.37	1224	0.28	981	0.20	---	---
0.6	1610	0.51	1383	0.39	1124	0.28	856	0.19	---	---	---	---
0.8	1293	0.40	1021	0.29	776	0.20	---	---	---	---	---	---
1.0	948	0.29	614	0.17	---	---	---	---	---	---	---	---

HIGH-STATIC BELT DRIVE — DOWN SHOT

ESP (" H ₂ O)	TURNS OPEN											
	0		1		2		3		4		5	
	CFM	BHP	CFM	BHP	CFM	BHP	CFM	BHP	CFM	BHP	CFM	BHP
0.6	---	---	---	---	---	---	1655	0.53	1389	0.39	1103	0.28
0.8	---	---	---	---	1640	0.57	1342	0.43	1035	0.29	775	0.19
1.0	---	---	1638	0.63	1326	0.47	1002	0.32	713	0.19	---	---
1.2	1638	0.69	1307	0.52	984	0.36	---	---	---	---	---	---
1.4	1307	0.58	1002	0.42	---	---	---	---	---	---	---	---
1.6	1002	0.48	717	0.32	---	---	---	---	---	---	---	---
1.8	717	0.38	---	---	---	---	---	---	---	---	---	---

Note: Tables represent dry coil without filter; to compensate for filter, add 0.08" to measured E.S.P. SCFM correction for wet coil = 4%.

STANDARD DIRECT DRIVE — HORIZONTAL

CFM	STATIC	AMPS	WATTS	RPM	SPEED TAP
1293	0.1	1.72	364	715	Low
1235	0.2	1.67	354	759	
1173	0.3	1.62	342	803	
1124	0.4	1.58	330	841	
1056	0.5	1.54	316	880	
978	0.6	1.47	298	913	
1500	0.1	2.13	462	808	
1434	0.2	2.10	448	838	
1381	0.3	2.04	436	869	
1318	0.4	2.00	424	902	
1238	0.5	1.94	406	929	
1163	0.6	1.88	392	951	
1055	0.7	1.80	370	990	
936	0.8	1.72	350	1017	
1441	0.4	2.35	504	940	High
1355	0.5	2.28	484	962	
1264	0.6	2.21	468	989	
1157	0.7	2.13	446	1012	
1027	0.8	2.03	418	1034	
840	0.9	1.90	388	1067	

STANDARD DIRECT DRIVE — DOWN SHOT

CFM	STATIC	AMPS	WATTS	RPM	SPEED TAP
1313	0.10	1.68	356	748	Low
1247	0.20	1.63	344	786	
1178	0.30	1.59	334	832	
1094	0.40	1.55	324	869	
1002	0.50	1.50	312	913	
919	0.60	1.45	296	940	
1471	0.10	2.11	454	830	
1400	0.20	2.06	440	863	
1354	0.30	2.02	432	896	
1271	0.40	1.95	416	929	
1188	0.50	1.90	398	957	
1083	0.60	1.82	378	984	
955	0.70	1.74	356	1012	
1470	0.30	2.37	510	935	High
1390	0.40	2.31	492	957	
1310	0.50	2.25	476	978	
1206	0.60	2.17	454	1000	
1098	0.70	2.09	436	1023	
966	0.80	1.99	412	1045	

NOTE: Assumes dry coil with filter in place; SCFM correction for wet coil = 4%

AIRFLOW DATA — 4 TONS

STANDARD DIRECT DRIVE — HORIZONTAL

CFM	STATIC	AMPS	WATTS	RPM	SPEED TAP
1592	0.1	2.54	543	815	Low
1528	0.2	2.43	521	858	
1464	0.3	2.32	499	901	
1380	0.4	2.21	475	930	
1296	0.5	2.10	451	959	
1828	0.1	3.08	665	892	Med
1700	0.2	2.75	601	924	
1606	0.3	2.61	563	966	
1531	0.4	2.48	537	990	
1401	0.5	2.32	503	1023	
1287	0.6	2.22	477	1045	
1123	0.7	2.05	441	1073	
1926	0.1	3.34	740	937	High
1825	0.2	3.18	700	965	
1712	0.3	3.03	660	989	
1598	0.4	2.87	626	1015	
1482	0.5	2.76	596	1032	
1357	0.6	2.62	564	1049	

STANDARD DIRECT DRIVE — DOWN SHOT

CFM	STATIC	AMPS	WATTS	RPM	SPEED TAP
1612	0.1	2.60	554	789	Low
1548	0.2	2.49	532	832	
1484	0.3	2.38	510	875	
1400	0.4	2.27	486	904	
1316	0.5	2.16	462	933	
1846	0.1	3.14	676	866	Med
1718	0.2	2.81	612	898	
1624	0.3	2.67	574	940	
1549	0.4	2.54	548	964	
1419	0.5	2.38	514	997	
1305	0.6	2.28	488	1019	
1141	0.7	2.11	452	1047	
1954	0.1	3.43	758	924	High
1853	0.2	3.27	718	952	
1740	0.3	3.12	678	976	
1626	0.4	2.96	644	1002	
1510	0.5	2.85	614	1019	
1385	0.6	2.71	582	1036	

Note: Assumes dry coil with filter in place; SCFM correction for wet coil = 4%

STANDARD BELT DRIVE — HORIZONTAL

ESP (" H ₂ O)	TURNS OPEN											
	0		1		2		3		4		5	
	CFM	BHP	CFM	BHP	CFM	BHP	CFM	BHP	CFM	BHP	CFM	BHP
0.2	---	---	---	---	---	---	---	---	1800	0.47	1556	0.35
0.4	---	---	---	---	2002	0.65	1708	0.49	1438	0.36	1167	0.22
0.6	---	---	1910	0.67	1612	0.50	1330	0.37	1030	0.23	---	---
0.8	1813	0.69	1571	0.54	1222	0.36	989	0.25	---	---	---	---
1.0	1478	0.56	1142	0.32	---	---	---	---	---	---	---	---
1.2	1107	0.41	---	---	---	---	---	---	---	---	---	---

HIGH-STATIC BELT DRIVE — HORIZONTAL

ESP (" H ₂ O)	TURNS OPEN											
	0		1		2		3		4		5	
	CFM	BHP	CFM	BHP	CFM	BHP	CFM	BHP	CFM	BHP	CFM	BHP
0.6	---	---	---	---	---	---	---	---	1894	0.66	1585	0.49
0.8	---	---	---	---	---	---	1839	0.71	1532	0.53	1223	0.37
1.0	---	---	---	---	1782	0.73	1477	0.55	1170	0.39	---	---
1.2	---	---	1786	0.80	1445	0.59	1115	0.40	---	---	---	---
1.4	1764	0.86	1426	0.64	1107	0.46	---	---	---	---	---	---
1.6	1446	0.72	1098	0.50	---	---	---	---	---	---	---	---
1.8	1099	0.56	---	---	---	---	---	---	---	---	---	---

STANDARD BELT DRIVE — DOWN SHOT

ESP (" H ₂ O)	TURNS OPEN											
	0		1		2		3		4		5	
	CFM	BHP	CFM	BHP	CFM	BHP	CFM	BHP	CFM	BHP	CFM	BHP
0.2	---	---	---	---	---	---	1891	0.56	1632	0.42	1391	0.30
0.4	---	---	---	---	1796	0.57	1533	0.43	1290	0.31	1055	0.19
0.6	1948	0.74	1744	0.61	1446	0.44	1206	0.32	910	0.19	---	---
0.8	1654	0.63	1409	0.48	1096	0.31	---	---	---	---	---	---
1.0	1337	0.50	987	0.28	---	---	---	---	---	---	---	---

HIGH-STATIC BELT DRIVE — DOWN SHOT

ESP (" H ₂ O)	TURNS OPEN											
	0		1		2		3		4		5	
	CFM	BHP	CFM	BHP	CFM	BHP	CFM	BHP	CFM	BHP	CFM	BHP
0.6	---	---	---	---	---	---	1989	0.77	1712	0.59	1433	0.44
0.8	---	---	---	---	1929	0.79	1662	0.63	1384	0.47	1106	0.33
1.0	---	---	1952	0.88	1622	0.67	1335	0.49	1056	0.34	---	---
1.2	1897	0.93	1611	0.73	1315	0.54	1008	0.36	---	---	---	---
1.4	1616	0.80	1298	0.59	1007	0.42	---	---	---	---	---	---
1.6	1316	0.66	1007	0.46	---	---	---	---	---	---	---	---
1.8	---	---	---	---	---	---	---	---	---	---	---	---

Note: Tables represent dry coil without filter; to compensate for filter, add 0.08" to measured E.S.P. SCFM correction for wet coil = 4%.

STANDARD DIRECT-DRIVE — HORIZONTAL

CFM	STATIC	AMPS	WATTS	RPM	SPEED TAP
1416	0.1	1.63	176	588	T1
1295	0.2	1.61	174	621	
1200	0.3	1.68	186	660	
1133	0.4	1.79	196	704	
1045	0.5	1.90	208	753	
1543	0.1	2.00	220	627	T2
1485	0.2	2.12	236	671	
1425	0.3	2.20	250	698	
1352	0.4	2.26	258	748	
1304	0.5	2.39	274	786	
2107	0.1	4.02	502	797	T3
2031	0.2	4.13	518	819	
1980	0.3	4.27	536	858	
1954	0.4	4.37	554	880	
1887	0.5	4.48	572	913	
1839	0.6	4.58	582	940	
1782	0.7	4.72	602	968	
2224	0.1	4.73	592	832	T4
2165	0.2	4.79	612	860	
2123	0.3	4.91	630	891	
2079	0.4	5.01	642	913	
2029	0.5	5.14	666	946	
1978	0.6	5.26	676	969	
1926	0.7	5.38	698	1001	
1872	0.8	5.48	712	1028	
1817	0.9	5.58	722	1056	
2318	0.1	5.42	700	874	T5
2296	0.2	5.55	720	903	
2228	0.3	5.66	734	929	
2193	0.4	5.76	748	950	
2145	0.5	5.90	766	979	
2097	0.6	5.99	784	1012	
2054	0.7	6.10	798	1034	
1991	0.8	6.15	810	1050	
1952	0.9	6.26	826	1079	

STANDARD DIRECT-DRIVE — DOWN SHOT

CFM	STATIC	AMPS	WATTS	RPM	SPEED TAP
1237	0.1	1.64	180	638	T1
1191	0.2	1.75	194	682	
1127	0.3	1.80	200	715	
1065	0.4	1.89	214	753	
994	0.5	1.97	220	797	
1437	0.1	2.13	248	687	T2
1384	0.2	2.24	254	726	
1312	0.3	2.29	262	759	
1245	0.4	2.42	280	803	
1185	0.5	2.54	294	847	
1988	0.1	4.49	558	885	T3
1942	0.2	4.58	574	907	
1882	0.3	4.69	582	935	
1847	0.4	4.80	600	962	
1784	0.5	4.87	612	990	
1762	0.6	4.97	626	1008	
1688	0.7	5.05	642	1039	
2106	0.1	5.14	650	924	T4
2050	0.2	5.26	670	951	
1993	0.3	5.32	678	969	
1960	0.4	5.47	696	1001	
1920	0.5	5.54	706	1021	
1880	0.6	5.61	726	1041	
1810	0.7	5.73	736	1072	
1760	0.8	5.81	750	1093	
1694	0.9	5.84	752	1122	
2199	0.1	5.87	762	968	T5
2146	0.2	5.96	772	989	
2121	0.3	6.06	788	1012	
2066	0.4	6.15	804	1039	
2010	0.5	6.21	814	1056	
1978	0.6	6.32	834	1084	
1919	0.7	6.28	830	1102	
1837	0.8	6.22	814	1122	
1738	0.9	6.04	786	1127	

NOTES

- Assumes dry coil with filter in place; SCFM correction for wet coil = 4%
- Five-ton models are shipped from the factory with speed tap set on T4.

STANDARD BELT DRIVE — HORIZONTAL

ESP (" H ₂ O)	TURNS OPEN											
	0		1		2		3		4		5	
	CFM	BHP	CFM	BHP	CFM	BHP	CFM	BHP	CFM	BHP	CFM	BHP
0.2	---	---	---	---	2460	0.96	2251	0.80	2073	0.65	1862	0.51
0.4	---	---	2408	1.00	2206	0.84	1982	0.68	1808	0.55	1572	0.41
0.6	2402	1.08	2173	0.89	1943	0.72	1701	0.55	1511	0.43	---	---
0.8	2153	0.95	1917	0.77	1667	0.59	---	---	---	---	---	---
1.0	1888	0.82	1634	0.63	---	---	---	---	---	---	---	---
1.2	1601	0.67	---	---	---	---	---	---	---	---	---	---

HIGH-STATIC BELT DRIVE — HORIZONTAL

ESP (" H ₂ O)	TURNS OPEN											
	0		1		2		3		4		5	
	CFM	BHP	CFM	BHP	CFM	BHP	CFM	BHP	CFM	BHP	CFM	BHP
0.6	---	---	---	---	---	---	---	---	2219	0.95	1970	0.75
0.8	---	---	---	---	---	---	2215	1.04	1956	0.82	1697	0.62
1.0	---	---	---	---	2240	1.15	1957	0.90	1681	0.67	---	---
1.2	---	---	2260	1.26	1983	1.00	1683	0.74	---	---	---	---
1.4	2288	1.38	2009	1.10	1711	0.84	---	---	---	---	---	---
1.6	2032	1.21	1741	0.93	---	---	---	---	---	---	---	---
1.8	1776	1.04	---	---	---	---	---	---	---	---	---	---

STANDARD BELT DRIVE — DOWN SHOT

ESP (" H ₂ O)	TURNS OPEN											
	0		1		2		3		4		5	
	CFM	BHP	CFM	BHP	CFM	BHP	CFM	BHP	CFM	BHP	CFM	BHP
0.2	---	---	2210	0.91	2041	0.76	1869	0.63	1739	0.52	1565	0.40
0.4	2197	0.98	2021	0.82	1841	0.67	1660	0.54	1521	0.44	1339	0.32
0.6	2002	0.88	1822	0.72	1635	0.58	1445	0.44	1288	0.35	---	---
0.8	1799	0.77	1610	0.62	1425	0.48	---	---	---	---	---	---
1.0	1587	0.67	1384	0.51	---	---	---	---	---	---	---	---

HIGH-STATIC BELT DRIVE — DOWN SHOT

ESP (" H ₂ O)	TURNS OPEN											
	0		1		2		3		4		5	
	CFM	BHP	CFM	BHP	CFM	BHP	CFM	BHP	CFM	BHP	CFM	BHP
0.6	---	---	---	---	2262	1.16	2051	0.95	1851	0.76	1657	0.60
0.8	---	---	2277	1.27	2070	1.05	1852	0.84	1646	0.66	---	---
1.0	2304	1.39	2089	1.15	1872	0.93	1647	0.72	---	---	---	---
1.2	2104	1.26	1893	1.03	1668	0.81	---	---	---	---	---	---
1.4	1912	1.13	1690	0.90	---	---	---	---	---	---	---	---
1.6	1720	1.00	---	---	---	---	---	---	---	---	---	---

Note: Tables represent dry coil without filter; to compensate for filter, add 0.08" to measured E.S.P. SCFM correction for wet coil = 4%.

DCG072 STANDARD BELT DRIVE AND TWO-SPEED STANDARD BELT DRIVE AT HIGH SPEED - HORIZONTAL

ESP (In W.C.)	0 TURNS		1 TURN		2 TURNS		3 TURNS		4 TURNS		5 TURNS	
	CFM	BHP	CFM	BHP	CFM	BHP	CFM	BHP	CFM	BHP	CFM	BHP
0.2	---	---	---	---	---	---	2749	1.18	2573	0.96	2402	0.79
0.4	---	---	---	---	2680	1.22	2544	1.06	2346	0.84	2164	0.68
0.6	---	---	2655	1.31	2498	1.10	2306	0.92	2094	0.72	1890	0.57
0.8	2703	1.47	2486	1.20	2263	0.97	2076	0.81	---	---	---	---
1	2515	1.34	2272	1.07	2002	0.83	---	---	---	---	---	---
1.2	2253	1.16	2028	0.93	---	---	---	---	---	---	---	---

DCG072 STANDARD BELT DRIVE AND TWO-SPEED STANDARD BELT DRIVE AT HIGH SPEED - DOWN SHOT

ESP (In W.C.)	0 TURNS		1 TURN		2 TURNS		3 TURNS		4 TURNS		5 TURNS	
	CFM	BHP	CFM	BHP	CFM	BHP	CFM	BHP	CFM	BHP	CFM	BHP
0.2	---	---	---	---	2625	1.18	2486	1.02	2322	0.83	2152	0.68
0.4	2765	1.52	2596	1.28	2476	1.09	2327	0.94	2159	0.75	1938	0.59
0.6	2650	1.43	2452	1.18	2325	1.00	2070	0.80	1898	0.64	---	---
0.8	2443	1.29	2251	1.06	2068	0.86	1868	0.71	---	---	---	---
1	2258	1.17	2040	0.94	1806	0.73	---	---	---	---	---	---
1.2	2021	1.02	---	---	---	---	---	---	---	---	---	---

HIGH STATIC BELT DRIVE — HORIZONTAL

ESP (In W.C.)	0 TURNS		1 TURN		2 TURNS		3 TURNS		4 TURNS		5 TURNS	
	CFM	BHP	CFM	BHP	CFM	BHP	CFM	BHP	CFM	BHP	CFM	BHP
0.6	---	---	---	---	---	---	---	---	2677	1.29	2486	1.07
0.8	---	---	---	---	---	---	2690	1.42	2529	1.20	2263	0.94
1	---	---	---	---	2740	1.60	2471	1.27	2246	1.02	1972	0.79
1.2	---	---	2748	1.74	2518	1.44	2255	1.13	1970	0.87	---	---
1.4	2797	1.87	2562	1.59	2273	1.27	2025	0.99	---	---	---	---
1.6	2556	1.67	2314	1.40	2035	1.11	---	---	---	---	---	---
1.8	2342	1.50	2037	1.21	---	---	---	---	---	---	---	---
2	2137	1.35	---	---	---	---	---	---	---	---	---	---

HIGH STATIC BELT DRIVE — DOWN SHOT

ESP (In W.C.)	0 TURNS		1 TURN		2 TURNS		3 TURNS		4 TURNS		5 TURNS	
	CFM	BHP	CFM	BHP	CFM	BHP	CFM	BHP	CFM	BHP	CFM	BHP
0.6	---	---	---	---	2793	1.64	2575	1.37	2407	1.15	2250	0.96
0.8	---	---	2775	1.76	2638	1.53	2407	1.25	2226	1.04	2011	0.84
1	2821	1.89	2660	1.67	2407	1.36	2194	1.12	2012	0.92	---	---
1.2	2696	1.79	2497	1.54	2228	1.23	1977	0.98	---	---	---	---
1.4	2455	1.59	2236	1.35	2013	1.10	---	---	---	---	---	---
1.6	2262	1.44	2032	1.20	---	---	---	---	---	---	---	---
1.8	2069	1.30	---	---	---	---	---	---	---	---	---	---

AIR FLOW PRESSURE DROP OF DOWN FLOW ECONOMIZER

AIRFLOW PRESSURE DROP OF DOWNFLOW ECONOMIZER FOR 3 TO 6 TON ROFTOP UNITS (100% RETURN AIR)											
SCF,	800	1000	1200	1400	1600	1800	2000	2200	2400	2600	2800
in WG	0.02	0.04	0.05	0.07	0.09	0.12	0.14	0.17	0.21	0.24	0.28

MODEL TONNAGES	"A"	"B"	"C"
3 TON COMMERCIAL GAS, HT PUMP, AIR CONDITIONER	38.840	16.555	26.055
4 TON COMMERCIAL GAS, HT PUMP, AIR CONDITIONER	38.840	16.555	26.055
5 TON COMMERCIAL GAS, HT PUMP, AIR CONDITIONER	38.840	16.555	26.055
6 TON COMMERCIAL GAS, HT PUMP, AIR CONDITIONER	42.840	20.555	30.055

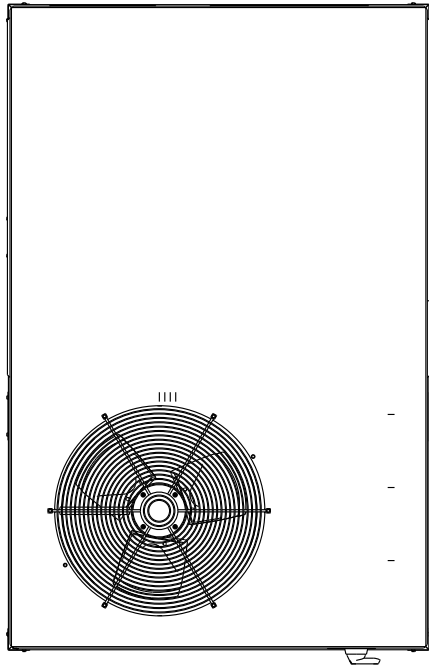

TOP VIEW

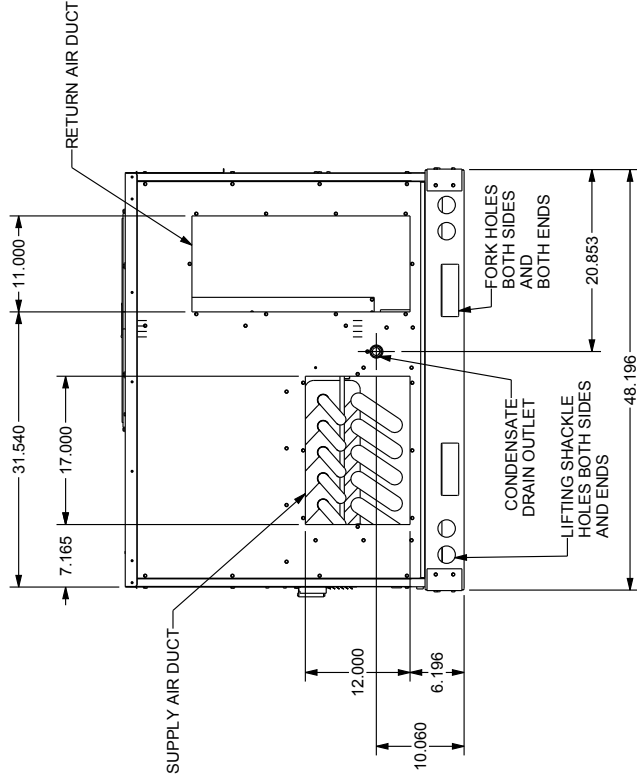

RIGHT END VIEW

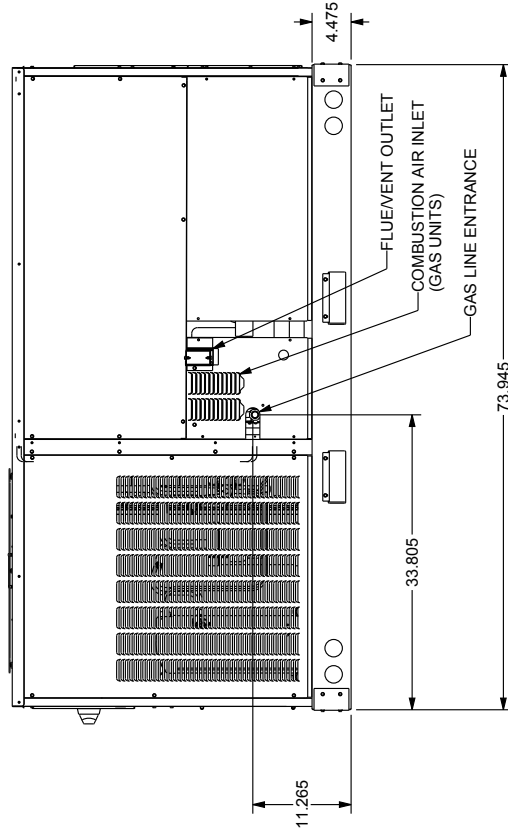

FRONT VIEW

DC*036-072***
3 THRU 6 TON COMMERCIAL

ALL DIMENSIONS GIVEN ARE IN INCHES.
ALL DIMENSIONS AND SPECIFICATIONS ARE SUBJECT TO CHANGE WITHOUT NOTICE

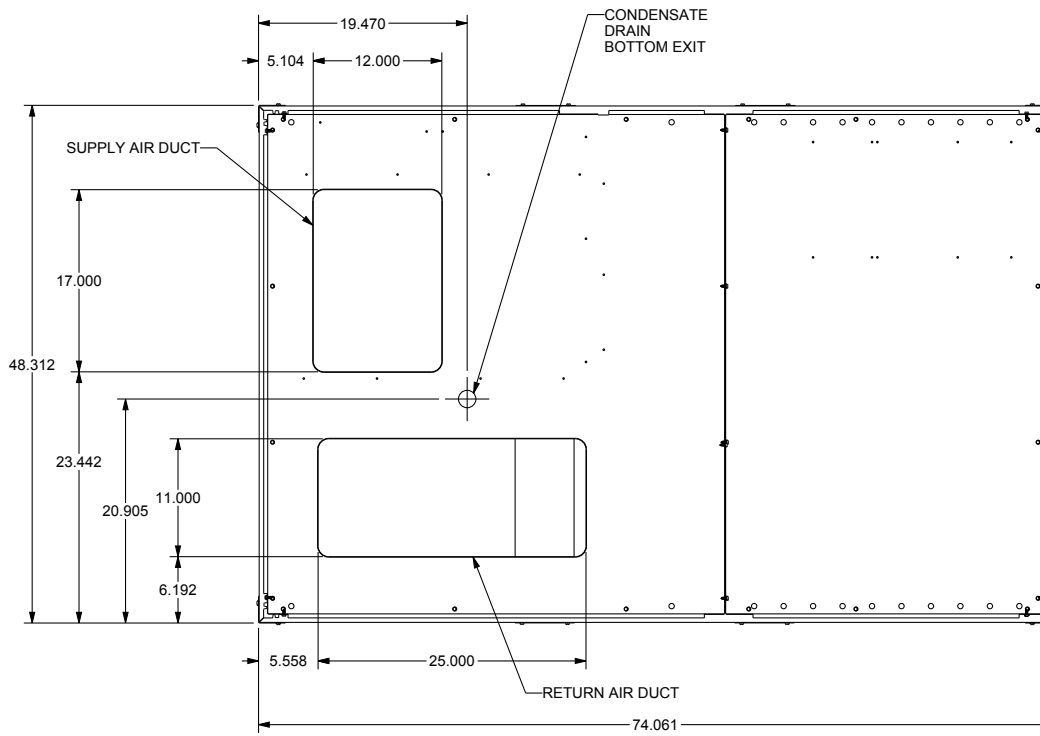

BASE PAN VIEW
(VIEWED FROM TOP)

MODEL TONNAGES	"A"	"B"	"C"
3 TON COMMERCIAL GAS, HT PUMP, AIR CONDITIONER	38.840	16.555	26.055
4 TON COMMERCIAL GAS, HT PUMP, AIR CONDITIONER	38.840	16.555	26.055
5 TON COMMERCIAL GAS, HT PUMP, AIR CONDITIONER	38.840	16.555	26.055
6 TON COMMERCIAL GAS, HT PUMP, AIR CONDITIONER	42.840	20.555	30.055

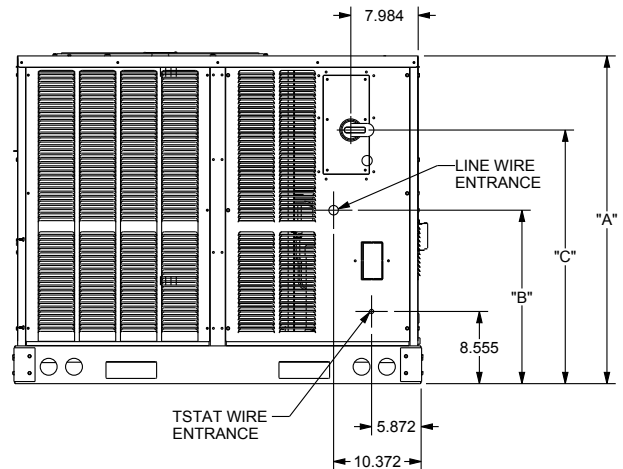

LEFT END VIEW

UNIT CLEARANCES

Maintain an adequate clearance around the unit for safety, service, maintenance, and proper unit operation. Leave a total clearance of 75" on the main control panel side of the unit for possible removal of fan shaft, coil, electric heat, and gas furnace. Leave a clearance of 48" on all other sides of the unit for possible compressor removal or service access, and to ensure proper ventilation and condenser airflow. Do not install the unit Beneath any obstruction. Install the unit away from all building exhausts to inhibit ingestion of exhaust air into the unit's fresh-air intake.

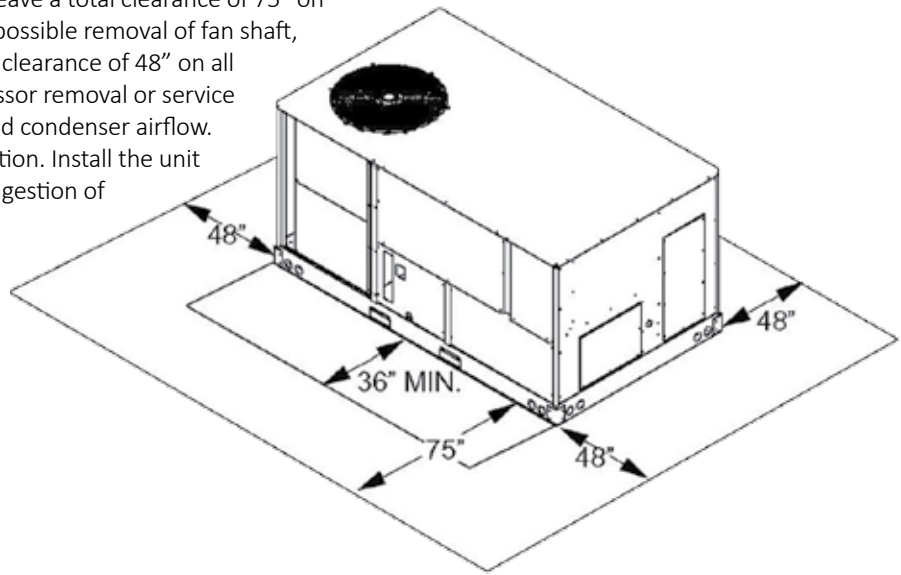

ELECTRICAL ENTRANCE LOCATIONS

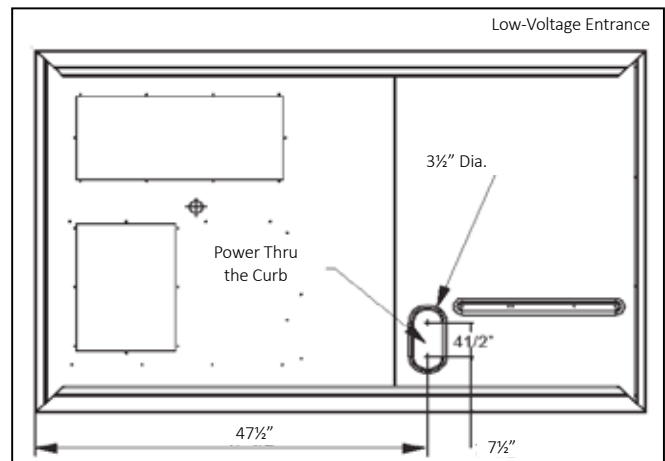
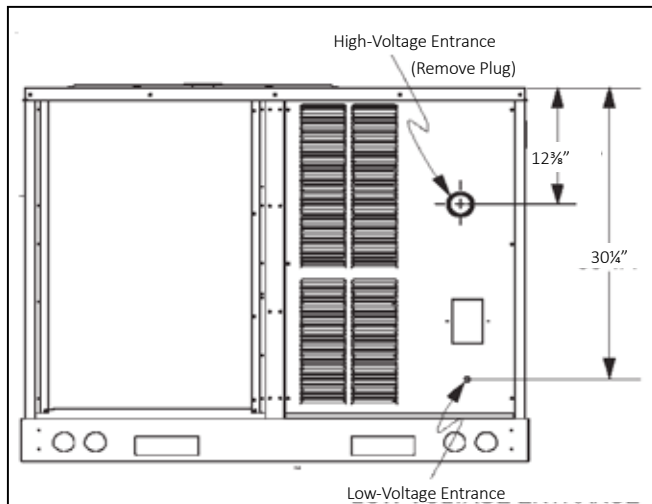

CORNER & CENTER-OF-GRAVITY LOCATIONS

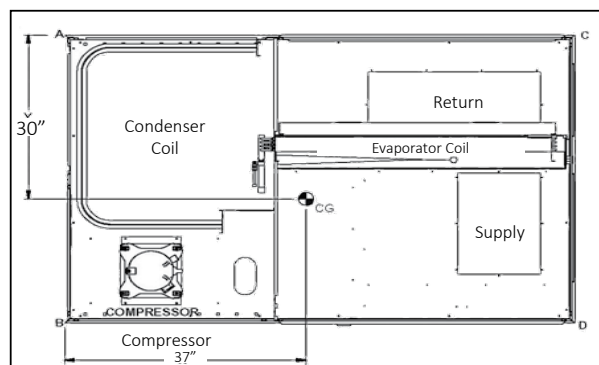

UNIT WEIGHTS	3-TON WEIGHTS	4-TON WEIGHTS	5-TON WEIGHTS	6-TON WEIGHTS
Corner Weight (A)	100	110	115	130
Corner Weight (B)	170	180	195	215
Corner Weight (C)	105	110	120	130
Corner Weight (D)	170	180	195	215
Unit Shipping Weight	560	605	650	715
Unit Operating Weight	545	580	625	690

Note: Weights are calculated without accessories installed.

Provisions for forks have been included in the unit base frame. No other fork locations are approved.

- Unit must be lifted by the four lifting holes located at the base frame corners.
- Lifting cables should be attached to the unit with shackles.
- The distance between the crane hook and the top of the unit must not be less than 60".
- Two spreader bars must span over the unit to prevent damage to the cabinet by the lift cables. Spreader bars must be of sufficient length so that cables do not come in contact with the unit during transport. Remove wood struts mounted beneath unit base frame before setting unit on roof curb. These struts are intended to protect unit base frame from fork lift damage. To remove the struts, extract the sheet metal retainers and pull the struts through the base of the unit. Refer to rigging label on the unit.

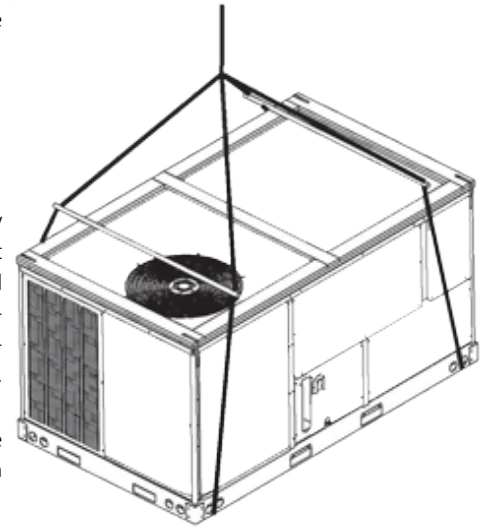

Important: If using bottom discharge with roof curb, duct-work should be attached to the curb prior to installing the unit. Duct-work dimensions are shown in Roof Curb Installation Instructions Manual.

Refer to the Roof Curb Installation Instructions for proper curb installation. Curbing must be installed in compliance with the National Roofing Contractors Association Manual.

Lower unit carefully onto roof mounting curb. While rigging the unit, the center of gravity will cause the condenser end to be lower than the supply air end.

Bring condenser end of unit into alignment with the curb. With condenser end of the unit resting on curb member and using curb as a fulcrum, lower opposite end of the unit until entire unit is seated on the curb. When a rectangular cantilever curb is used, take care to center the unit. Check for proper alignment and orientation of supply and return openings with duct.

To assist in determining rigging requirements, unit weights are shown below.

Curb installations must comply with local codes and should follow the established guidelines of the National Roofing Contractors Association.

Proper unit installation requires that the roof curb be firmly and permanently attached to the roof structure. Check for adequate fastening method prior to setting the unit on the curb.

Full perimeter roof curbs are available from the factory and are shipped unassembled. The installing contractor is responsible for field assembly, squaring, leveling, and mounting on the roof structure. All required hardware necessary for the assembly of the sheet metal curb is included in the curb accessory package.

- Determine sufficient structural support before locating and mounting the curb and package unit.
- Duct-work must be constructed using industry guidelines. The duct-work must be placed into the roof curb before mounting the package unit. Our full perimeter curbs include duct connection frames to be assembled with the curb. Cantilevered-type curbs are not available from the factory.
- Contractor furnishes curb insulation, cant strips, flashing, and general roofing material.
- Support curbs on parallel sides with roof members. To prevent damage to the unit, the roof members cannot penetrate supply and return duct openings.

Note: The unit and curb accessories are designed to allow vertical duct installation before unit placement. Duct installation after unit placement is not recommended.

See the manual shipped with the roof curb for assembly and installation instructions.

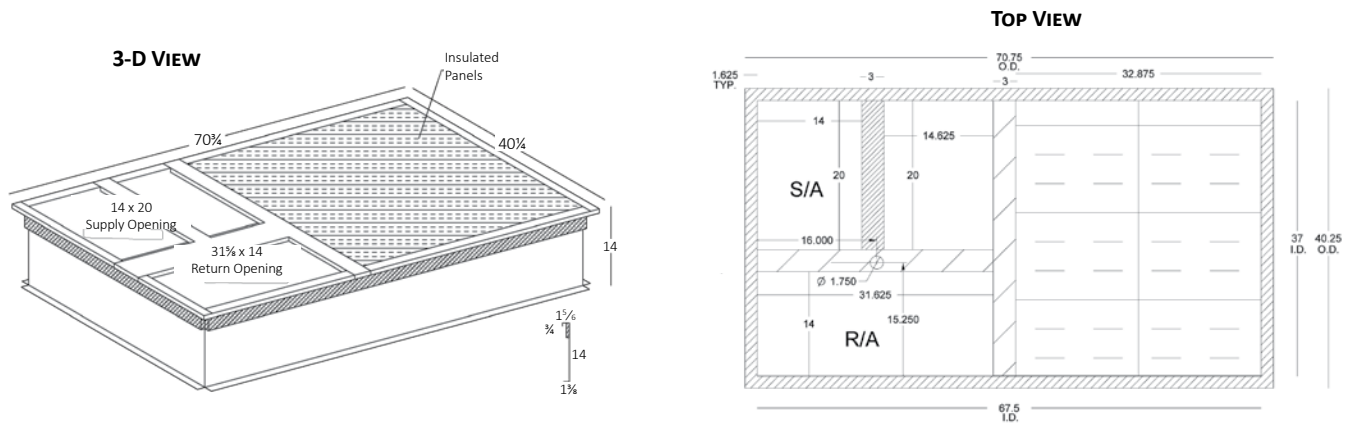

WIRING DIAGRAM — DCG 3 TONS (230V, THREE PHASE, DIRECT DRIVE)

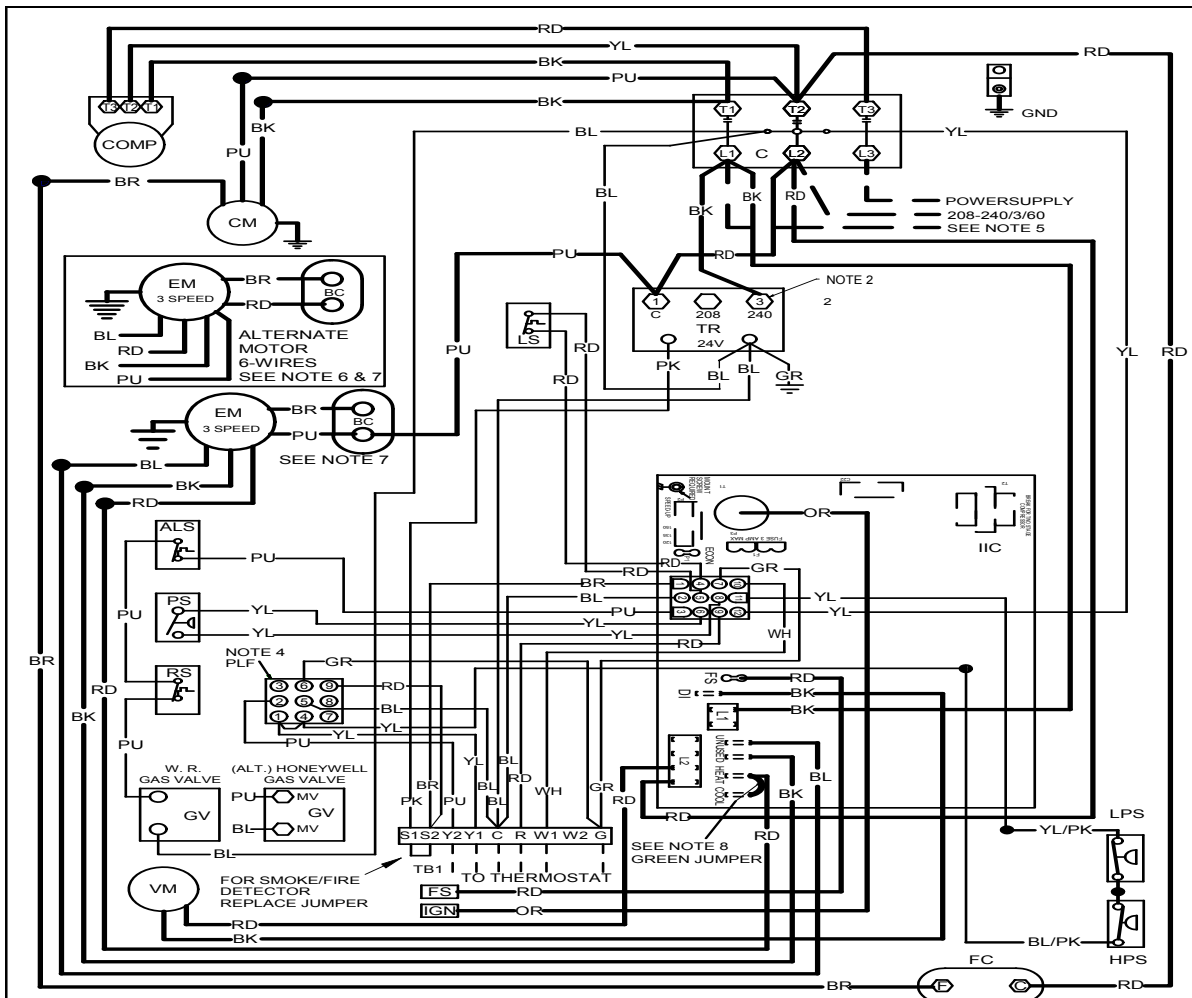

High Voltage: Disconnect all power before servicing or installing this unit. Multiple power sources may be present. Failure to do so may cause property damage, personal injury, or death.

WARNING

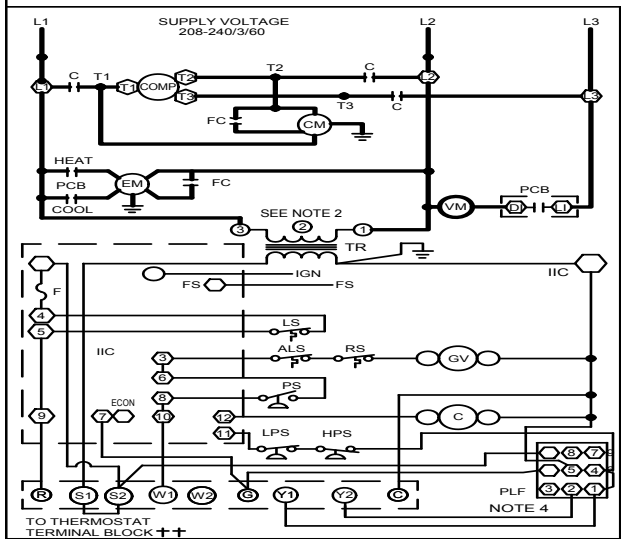

- COMPONENT LEGEND**
- ALS AUXILIARY LIMIT SWITCH
 - COMP COMPRESSOR
 - CM CONDENSER MOTOR
 - C CONTACTOR
 - EM EVAPORATOR MOTOR
 - F FUSE
 - FC FAN CAPACITOR
 - FS FLAME SENSOR
 - GND EQUIPMENT GROUND
 - GV GAS VALVE
 - HPS HIGH PRESSURE SWITCH
 - IIC INTEGRATED IGNITION CONTROL
 - IGN IGNITOR
 - LS LIMIT SWITCH
 - LPS LOW PRESSURE SWITCH
 - PLF FEMALE PLUG/CONNECTOR
 - PS PRESSURE SWITCH
 - RS ROLLOUT SWITCH
 - TB1 TERMINAL BLOCK (24V SIGNAL)
 - VM VENT MOTOR
 - VMR VENT MOTOR RELAY
 - BC BLOWER CAPACITOR

- FACTORY WIRING**
- LINE VOLTAGE
 - LOW VOLTAGE
 - - - OPTIONAL HIGH VOLTAGE
- FIELD WIRING**
- - - HIGH VOLTAGE
 - - - LOW VOLTAGE
- WIRE CODE**
- BK BLACK
 - BL BLUE
 - BR BROWN
 - GR GREEN
 - OR ORANGE
 - PK PINK
 - PU PURPLE
 - RD RED
 - WH WHITE
 - YL YELLOW
 - BL/PK BLUE WITH PINK STRIP
 - YL/PK YELLOW WITH PINK STRIP

- NOTES**
1. REPLACEMENT WIRE MUST BE THE SAME SIZE AND TYPE OF INSULATION AS ORIGINAL. (USE COPPER CONDUCTOR ONLY).
 2. FOR 208 VOLT TRANSFORMER OPERATION MOVE BLACK WIRE FROM TERMINAL ② TO TERMINAL ③ ON TRANSFORMER.
 3. FOR DIFFERENT THAN FACTORY SPEED TAP. CHANGE COIL SPEED AT COOL TERMINAL. CHANGE HEATING SPEED AT HEAT TERMINAL ON CONTROL BOARD.
 4. ACCESSORY ECONOMIZER PLUG ADJACENT TO BLOWER HOUSING IN RETURN AIR COMPARTMENT. REMOVE MALE PLUG AND ATTACH FEMALE PLUG TO ECONOMIZER ACCESSORY.
 5. USE COPPER CONDUCTORS ONLY. **+** USE NEC CLASS 2 WIRE.
 6. PURPLE WIRE CONNECTS TO TRANSFORMER (PIN 1).
 7. SPEED TAP TERMINATIONS SHOWN ON DIAGRAM ARE REPRESENTATIVE. BUT ACTUAL FACTORY SETTING MAY BE DIFFERENT BASED ON HEATING VALUE AND CAPACITY OF UNIT.
 8. TO RUN AT DIFFERENT SPEED FOR HEATING AND COOLING, DISCONNECT GREEN JUMPER FROM "COOL" TERMINAL AND REPLACE WITH APPROPRIATE SPEED TAP. THEN PLACE DISCONNECTED END OF JUMPER ON "UNUSED" TERMINAL LEFT OPEN BY MOVING THE SPEED TAP.

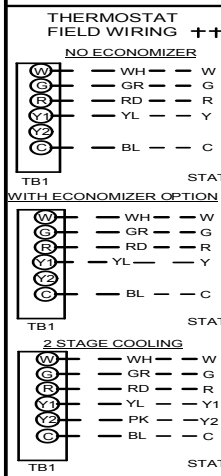

INSTALLER/SERVICEMAN

THE STATUS LIGHT ON THE FURNACE CONTROL MAY BE USED AS A GUIDE TO TROUBLESHOOTING THIS APPLIANCE. STATUS LIGHT CODES ARE AS FOLLOWS:

STATUS LIGHT	EQUIP. STATUS	CHECK
ON	NORMAL OPERATION	-
OFF	NO POWER OR INTERNAL CONTROL FAULT	CHECK INPUT POWER CHECK FUSE ON CONTROL REPLACE CONTROL
1 BLINK	IGNITION FAILURE OR OPEN ROLLOUT SWITCH OR OPEN AUX LIMIT SWITCH	CHECK GAS FLOW GAS PRESSURE GAS VALVE FLAME SENSOR FLAME ROLLOUT BAD SWITCH AUX. LIMIT OPEN SWITCH
2 BLINKS	PRESSURE SWITCH OPEN	CHECK PRESSURE SWITCH
3 BLINKS	PRESSURE SWITCH CLOSED WITHOUT INDUCER ON	CHECK PRESSURE SWITCH
4 BLINKS	OPEN LIMIT SWITCH	CHECK MAIN LIMIT OPEN BAD SWITCH
5 BLINKS	FALSE FLAME SENSED	CHECK STICKING GAS VALVE
6 BLINKS	COMPRESSOR OUTPUT DELAY	CHECK 3 MIN. COMP. ANTI-CYCLE TIMER

208-240/3/60 0140L02902-A



Wiring is subject to change. Always refer to the wiring diagram on the unit for the most up-to-date wiring.

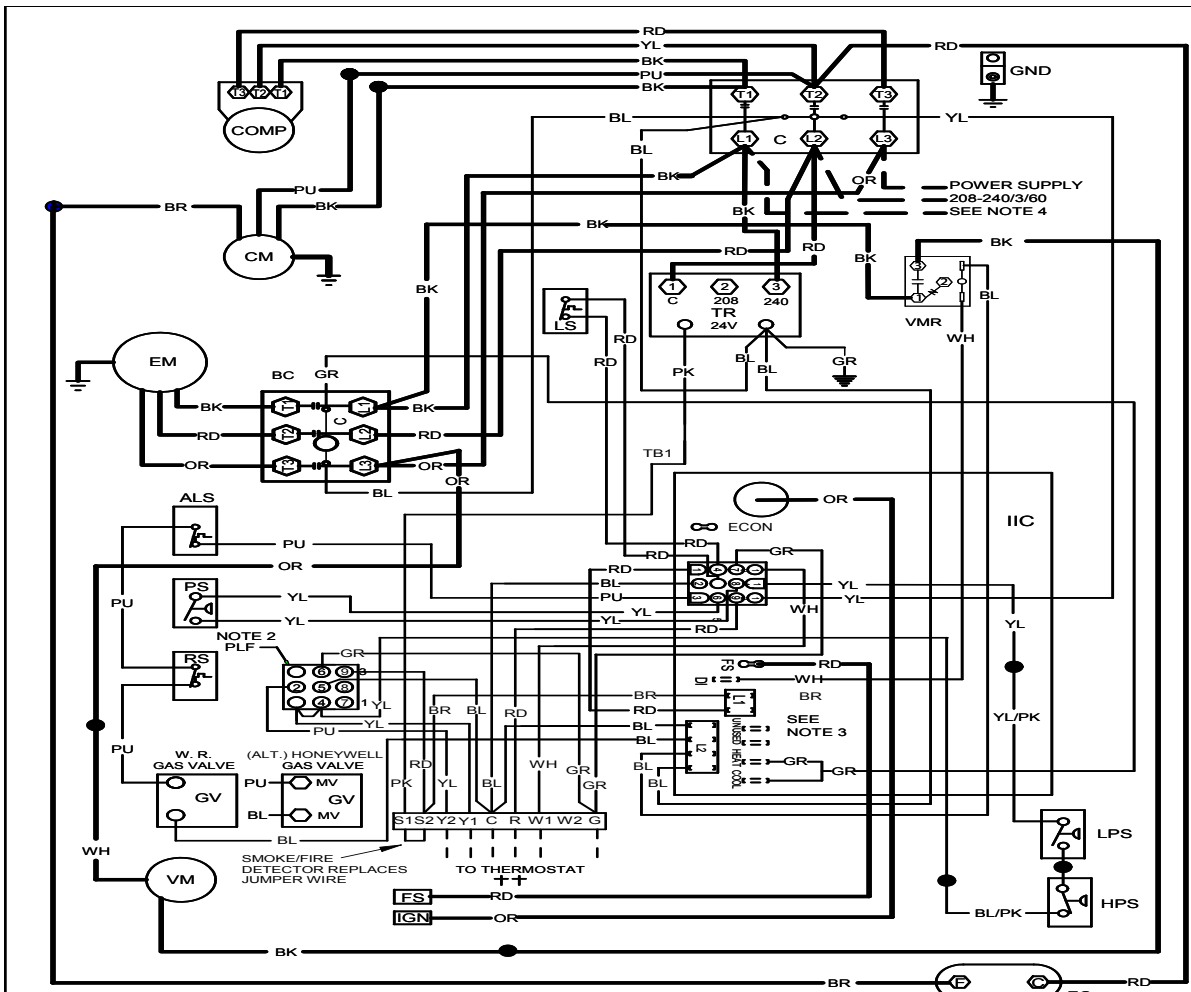

High Voltage: Disconnect all power before servicing or installing this unit. Multiple power sources may be present. Failure to do so may cause property damage, personal injury, or death.

WARNING

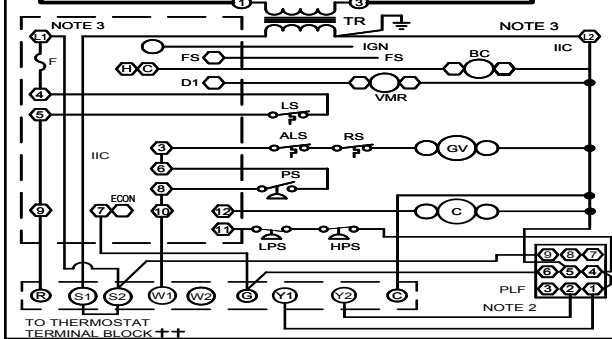
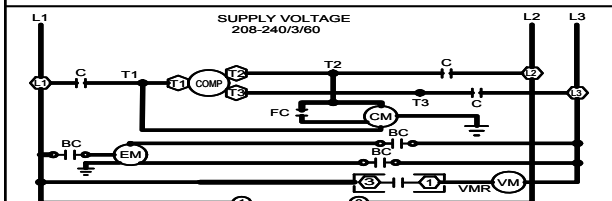

- COMPONENT LEGEND**
- ALS AUXILIARY LIMIT SWITCH
 - BC BLOWER CONTACTOR
 - COMP COMPRESSOR
 - CM CONDENSER MOTOR
 - C CONTACTOR
 - EM EVAPORATOR MOTOR
 - F FUSE
 - FC FAN CAPACITOR
 - FS FLAME SENSOR
 - GND EQUIPMENT GROUND
 - GV GAS VALVE
 - HPS HIGH PRESSURE SWITCH
 - IBR INDOOR BLOWER RELAY
 - IIC INTEGRATED IGNITION CONTROL
 - IGN IGNITOR
 - LS LIMIT SWITCH
 - PLF FEMALE PLUG/CONNECTOR
 - PS PRESSURE SWITCH
 - RS ROLLOUT SWITCH
 - TB1 TERMINAL BLOCK (24V SIGNAL)
 - TR TRANSFORMER
 - VM VENT MOTOR
 - VMR VENT MOTOR RELAY

- FACTORY WIRING**
- LINE VOLTAGE
 - LOW VOLTAGE
 - - - - - OPTIONAL HIGH VOLTAGE
- FIELD WIRING**
- - - - - HIGH VOLTAGE
 - - - - - LOW VOLTAGE
- WIRE CODE**
- BK BLACK
 - BL BLUE
 - BR BROWN
 - GR GREEN
 - OR ORANGE
 - PK PINK
 - PU PURPLE
 - RD RED
 - WH WHITE
 - YL YELLOW
 - BL/PK BLUE WITH PINK STRIP
 - YL/PK YELLOW WITH PINK STRIP

- NOTES**
1. REPLACEMENT WIRE MUST BE THE SAME SIZE AND TYPE OF INSULATION AS ORIGINAL (USE COPPER CONDUCTOR ONLY).
 2. ACCESSORY ECONOMIZER PLUG ADJACENT TO BLOWER HOUSING IN RETURN AIR COMPARTMENT. REMOVE MALE PLUG AND ATTACH FEMALE PLUG TO THE ECONOMIZER ACCESSORY.
 3. L1 AND L2 ON IIC CONTROL IS 24V INPUT.
 4. USE COPPER CONDUCTORS ONLY. †† USE NEC CLASS 2 WIRE.
 5. FOR 208 VOLT TRANSFORMER OPERATION, MOVE BLACK WIRE FROM TERMINAL (3) TO TERMINAL (2) ON TRANSFORMER.

SEE UNIT RATING PLATE FOR TYPE AND SIZE OF OVER CURRENT PROTECTION

INSTALLER/SERVICEMAN

THE STATUS LIGHT ON THE FURNACE CONTROL MAY BE USED AS A GUIDE TO TROUBLESHOOTING THIS APPLIANCE. STATUS LIGHT CODES ARE AS FOLLOWS:

STATUS LIGHT	EQUIP. STATUS	CHECK
ON	NORMAL OPERATION	-
OFF	NO POWER OR INTERNAL CONTROL	CHECK INPUT POWER CHECK FUSE ON CONTROL REPLACE CONTROL
1 BLINK	IGNITION FAILURE OPEN ROLLOUT SWITCH OPEN AUX. LIMIT SWITCH	CHECK GAS FLOW GAS PRESSURE GAS VALVE FLAME SENSOR FLAME ROLLOUT BAD SWITCH AUX. LIMIT OPEN
2 BLINKS	PRESSURE SWITCH OPEN	CHECK PRESSURE SWITCH
3 BLINKS	PRESSURE SWITCH CLOSED WITHOUT INDUCER ON	CHECK PRESSURE SWITCH
4 BLINKS	OPEN LIMIT SWITCH	CHECK MAIN LIMIT OPEN BAD SWITCH
5 BLINKS	FALSE FLAME SENSED	STICKING GAS VALVE
6 BLINKS	COMPRESSOR OUTPUT DELAY	3 MIN. COMP ANTI-CYCLE TIMER



208-240/3/60 0140L02901-A

WIRING DIAGRAM — DCG 3 TONS (460V, THREE PHASE, BELT DRIVE)

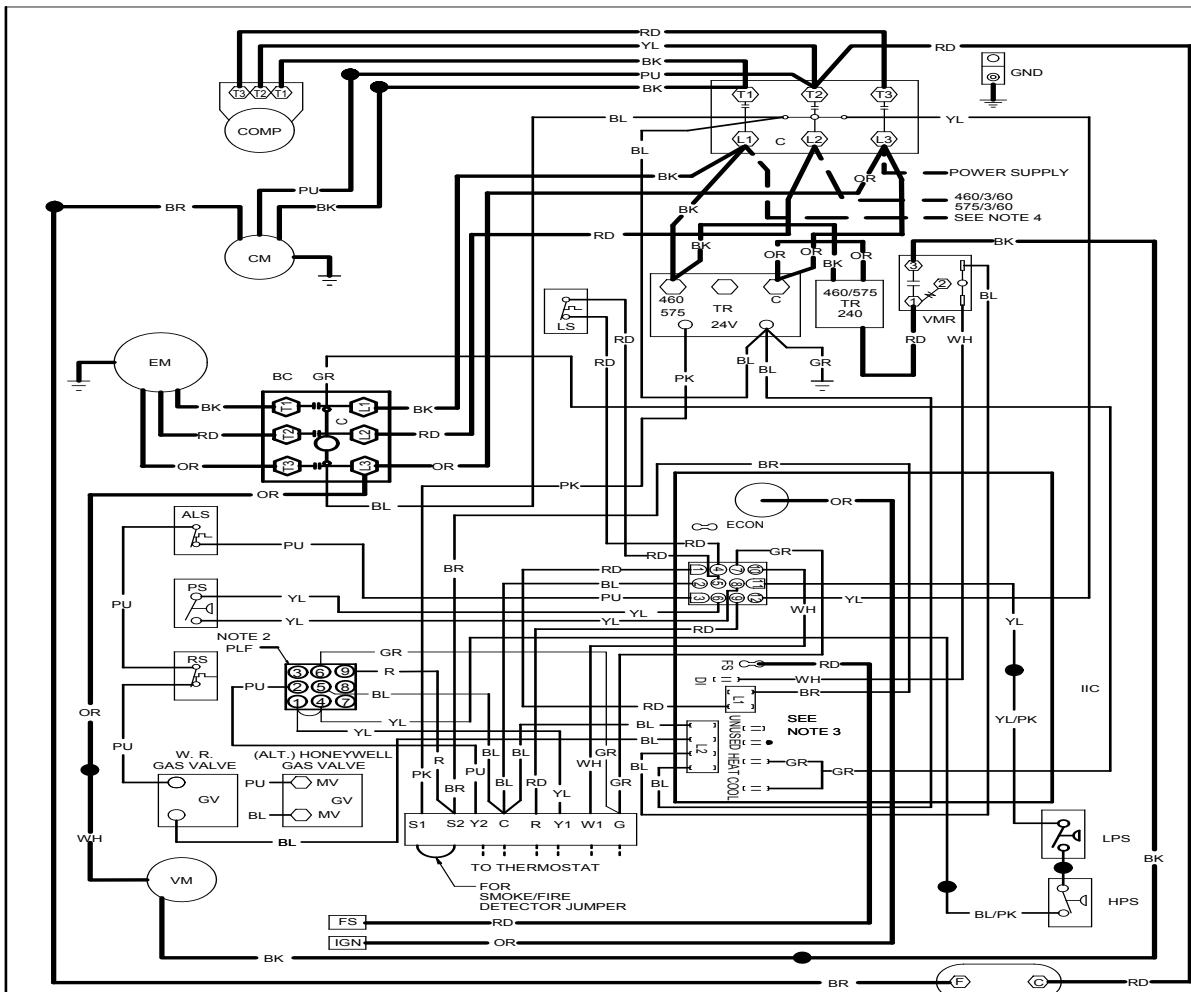

High Voltage: Disconnect all power before servicing or installing this unit. Multiple power sources may be present. Failure to do so may cause property damage, personal injury, or death.

WARNING

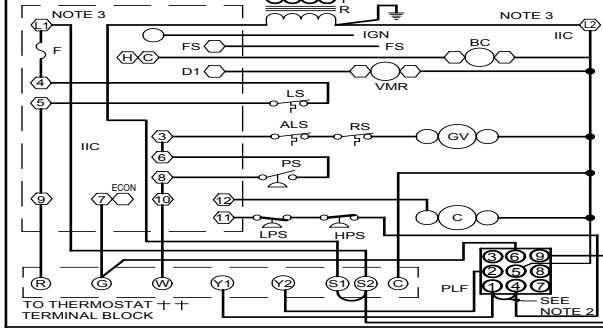
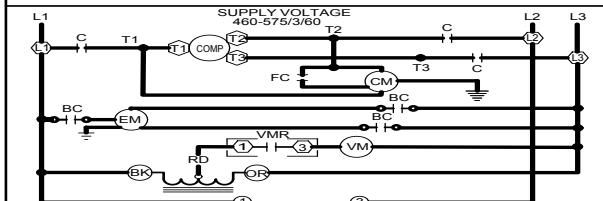

- COMPONENT LEGEND**
- ALS AUXILIARY LIMIT SWITCH
 - BC BLOWER CONTACTOR
 - COMP COMPRESSOR
 - CM CONDENSER MOTOR
 - CONTACTOR CONTACTOR
 - EM EVAPORATOR MOTOR
 - F FUSE
 - FC FAN CAPACITOR
 - FS FLAME SENSOR
 - GND EQUIPMENT GROUND
 - GV GAS VALVE
 - HPS HIGH PRESSURE SWITCH
 - IBR INDOOR BLOWER RELAY
 - IIC INTEGRATED IGNITION CONTROL
 - IGN IGNITOR
 - IGNR IGNITION RELAY
 - LS LIMIT SWITCH
 - PLF FEMALE PLUG/CONNECTOR
 - PS PRESSURE SWITCH
 - RS ROLL-OUT SWITCH
 - TB1 TERMINAL BLOCK (24V SIGNAL)
 - TR TRANSFORMER
 - VM VENT MOTOR
 - VMR VENT MOTOR RELAY

- FACTORY WIRING**
- LINE VOLTAGE
 - LOW VOLTAGE
 - OPTIONAL HIGH VOLTAGE
 - FIELD WIRING
 - HIGH VOLTAGE
 - LOW VOLTAGE
- WIRE CODE**
- BK BLACK
 - BL BLUE
 - BR BROWN
 - GR GREEN
 - OR ORANGE
 - PK PINK
 - PU PURPLE
 - RD RED
 - WH WHITE
 - YL YELLOW
 - YL/PK BLUE WITH PINK STRIP
 - YL/PK YELLOW WITH PINK STRIP

- NOTES**
1. REPLACEMENT WIRE MUST BE THE SAME SIZE AND TYPE OF INSULATION AS ORIGINAL (USE COPPER CONDUCTOR ONLY).
 2. ACCESSORY ECONOMIZER PLUG ADJACENT TO BLOWER HOUSING IN RETURN AIR COMPARTMENT. REMOVE MALE PLUG AND ATTACH FEMALE PLUG TO THE ECONOMIZER ACCESSORY.
 3. L1 AND L2 ON IIC CONTROL IS 24V INPUT.
 4. USE COPPER CONDUCTORS ONLY. ++ USE NEC CLASS 2 WIRE.

SEE UNIT RATING PLATE FOR TYPE AND SIZE OF OVER CURRENT PROTECTION.

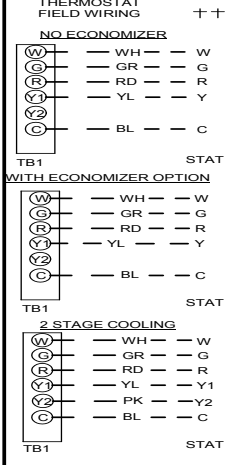

INSTALLER/SERVICEMAN
THE STATUS LIGHT ON THE FURNACE CONTROL MAY BE USED AS A GUIDE TO TROUBLESHOOTING THIS APPLIANCE. STATUS LIGHT CODES ARE AS FOLLOWS:

STATUS LIGHT	EQUIP. STATUS	CHECK
ON	NORMAL OPERATION	-
OFF	NO POWER OR INTERNAL CONTROL	CHECK INPUT POWER CHECK FUSE ON CONTROL REPLACE CONTROL
1 BLINK	IGNITION FAILURE OPEN ROLL-OUT SWITCH OPEN AUX. LIMIT SWITCH	CHECK GAS FLOW CHECK GAS VALVE CHECK FLAME SENSOR CHECK ROLL-OUT SWITCH CHECK AUX. LIMIT OPEN SWITCH
2 BLINKS	PRESSURE SWITCH OPEN	CHECK PRESSURE SWITCH
3 BLINKS	PRESSURE SWITCH CLOSED WITHOUT INDUCER ON	CHECK PRESSURE SWITCH
4 BLINKS	OPEN LIMIT SWITCH	MAIN LIMIT OPEN BAD SWITCH
5 BLINKS	FALSE FLAME SENSED	STICKING GAS VALVE
6 BLINKS	COMPRESSOR OUTPUT DELAY	3 MIN. COMP. ANTI-CYCLE TIMER



460-575/3/60 0140L02903-A

WIRING DIAGRAM — DCG 3 THROUGH 4 TONS (230V, THREE-PHASE, DIRECT DRIVE)

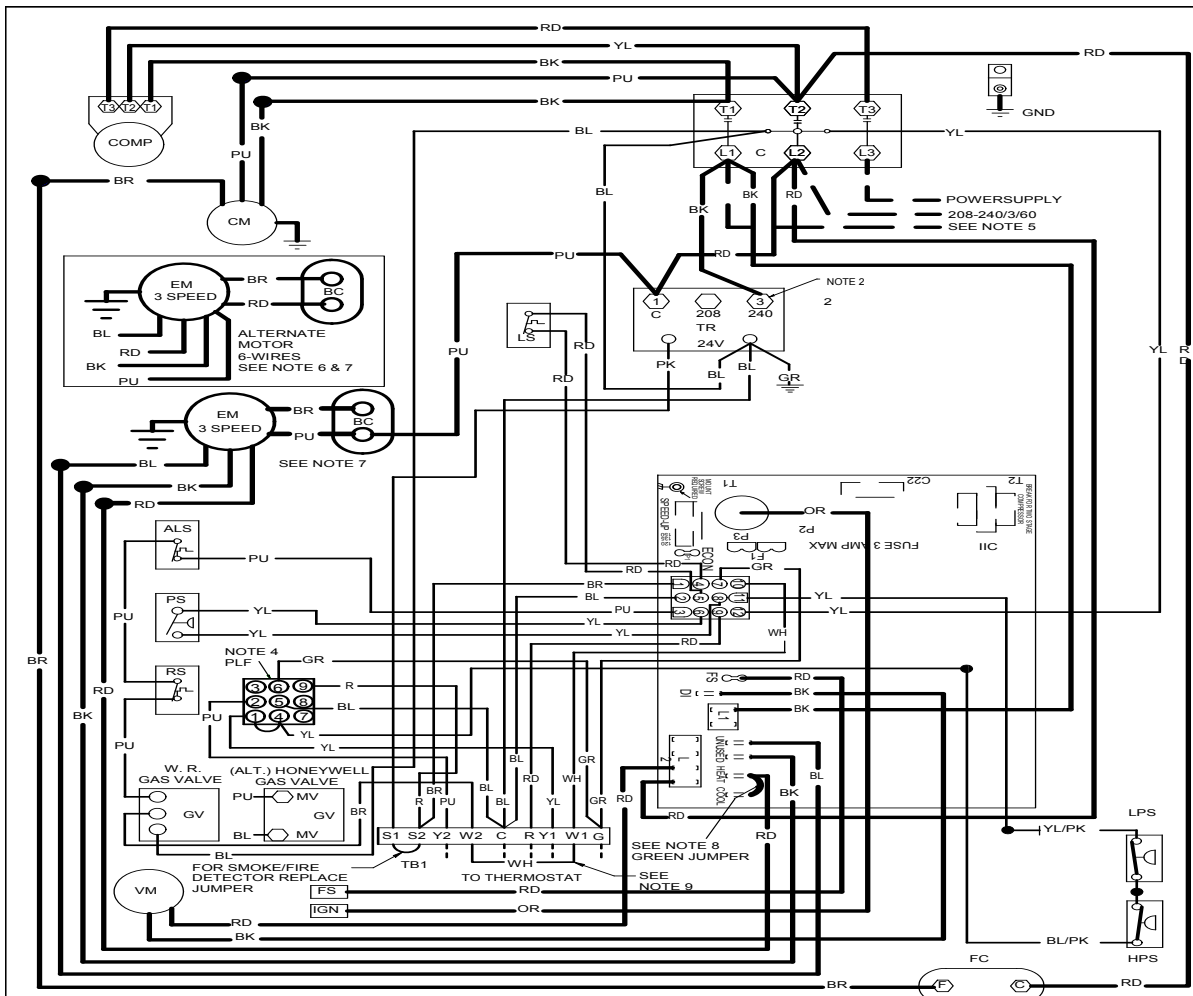

WARNING

High Voltage: Disconnect all power before servicing or installing this unit. Multiple power sources may be present. Failure to do so may cause property damage, personal injury, or death.

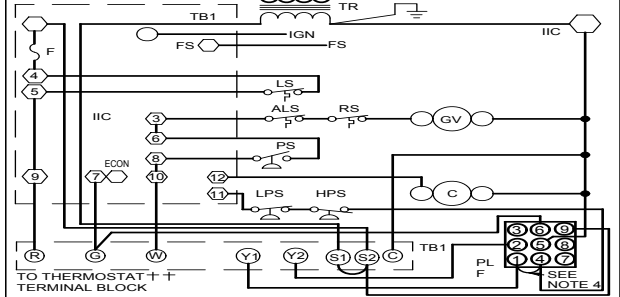
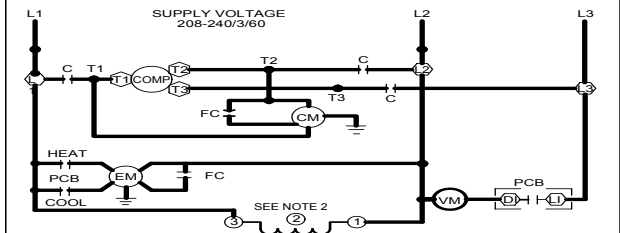

- COMPONENT LEGEND**
- ALS AUXILIARY LIMIT SWITCH
 - COMP COMPRESSOR
 - CM CONDENSER MOTOR
 - C CONTACTOR
 - EM EVAPORATOR MOTOR
 - FC FAN CAPACITOR
 - FS FLAME SENSOR
 - GND EQUIPMENT GROUND
 - GV GAS VALVE
 - HPS HIGH PRESSURE SWITCH
 - IIC INTEGRATED IGNITION CONTROL
 - IGN IGNITOR
 - LS LIMIT SWITCH
 - LPS LOW PRESSURE SWITCH
 - PLF FEMALE PLUG/CONNECTOR
 - PS PRESSURE SWITCH
 - RS ROLLOUT SWITCH
 - TB1 TERMINAL BLOCK (24V SIGNAL)
 - TR TRANSFORMER
 - VM VENT MOTOR
 - VMR VENT MOTOR RELAY
 - BC BLOWER CAPACITOR

- NOTES**
1. REPLACEMENT WIRE MUST BE THE SAME SIZE AND TYPE OF INSULATION AS ORIGINAL. (USE COPPER CONDUCTOR ONLY).
 2. FOR 208 VOLT TRANSFORMER OPERATION MOVE BLACK WIRE FROM TERMINAL (3) TO TERMINAL (2) ON TRANSFORMER.
 3. FOR DIFFERENT THAN FACTORY SPEED TAP, CHANGE COOLING SPEED AT COOL TERMINAL. CHANGE HEATING SPEED AT HEAT TERMINAL ON CONTROL BOARD.
 - 3 SPEED MOTOR
RD - LOW SPEED
BL - MED. SPEED
BK - HIGH SPEED
 4. ACCESSORY ECONOMIZER PLUG ADJACENT TO BLOWER NOISING IN RETURN AIR COMPARTMENT. REMOVE MALE PLUG AND ATTACH FEMALE PLUG TO ECONOMIZER ACCESSORY.
 5. USE COPPER CONDUCTORS ONLY.
 6. PURPLE WIRE CONNECTS TO TRANSFORMER (PIN 1).
 7. SPEED TAP TERMINATIONS SHOWN ON DIAGRAM ARE REPRESENTATIVE, BUT ACTUAL FACTORY SETTING MAY BE DIFFERENT BASED ON HEATING VALUE AND CAPACITY OF UNIT.
 8. TO RUN DIFFERENT SPEED FOR HEATING AND COOLING, DISCONNECT GREEN JUMPER FROM "COOL" TERMINAL AND REPLACE WITH APPROPRIATE SPEED TAP. THEN PLACE DISCONNECTED END OF JUMPER ON "UNUSED" TERMINAL LEFT OPEN BY MOVING THE SPEED TAP.
 9. FOR LOW STAGE OPERATION ONLY. REMOVE WHITE JUMPER. FOR 2 STAGE OPERATION, REMOVE JUMPER AND CONNECT W2 TO W1 ON THERMOSTAT.

- FACTORY WIRING**
- LINE VOLTAGE
 - LOW VOLTAGE
 - - - OPTIONAL HIGH VOLTAGE
- FIELD WIRING**
- - - HIGH VOLTAGE
 - - - LOW VOLTAGE

- WIRE CODE**
- BK BLACK
 - BL BLUE
 - BR BROWN
 - GR GREEN
 - OR ORANGE
 - PK PINK
 - PU PURPLE
 - RD RED
 - WH WHITE
 - YL YELLOW
 - YL/PK BLUE WITH PINK STRIP
 - Y/PK YELLOW WITH PINK STRIP

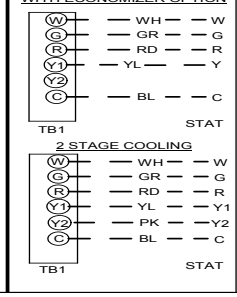
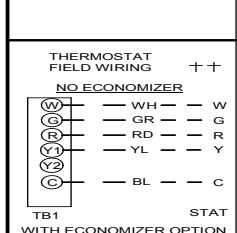

INSTALLER/SERVICEMAN

THE STATUS LIGHT ON THE FURNACE CONTROL MAY BE USED AS A GUIDE TO TROUBLESHOOTING THIS APPLIANCE. STATUS LIGHT CODES ARE AS FOLLOWS:

STATUS LIGHT	EQUIP. STATUS	CHECK
ON	NORMAL OPERATION	-
OFF	NO POWER OR INTERNAL CONTROL FAULT	CHECK INPUT POWER CHECK FUSE ON CONTROL
	IGNITION FAILURE	REPLACE CONTROL
1 BLINK	OPEN ROLL-OUT SWITCH OR OPEN AUX. LIMIT SWITCH	GAS FLOW GAS PRESSURE GAS VALVE FLAME SENSOR FLAME ROLL-OUT BAD SWITCH AUX. LIMIT OPEN
2 BLINKS	PRESSURE SWITCH OPEN	CHECK PRESSURE SWITCH
3 BLINKS	PRESSURE SWITCH CLOSED WITHOUT INDUCER ON	CHECK PRESSURE SWITCH
4 BLINKS	OPEN LIMIT SWITCH	MAIN LIMIT OPEN BAD SWITCH
5 BLINKS	FALSE FLAME SENSED	STICKING GAS VALVE
6 BLINKS	COMPRESSOR OUTPUT DELAY	3 MIN. COMP ANTI-CYCLE TIMER

SEE UNIT RATING PLATE FOR TYPE AND SIZE OF OVERCURRENT PROTECTION.

208-240/3/60 0140L02899-A

WIRING DIAGRAM — DCG 3 THROUGH 6 TONS (230V, THREE-PHASE, BELT DRIVE)

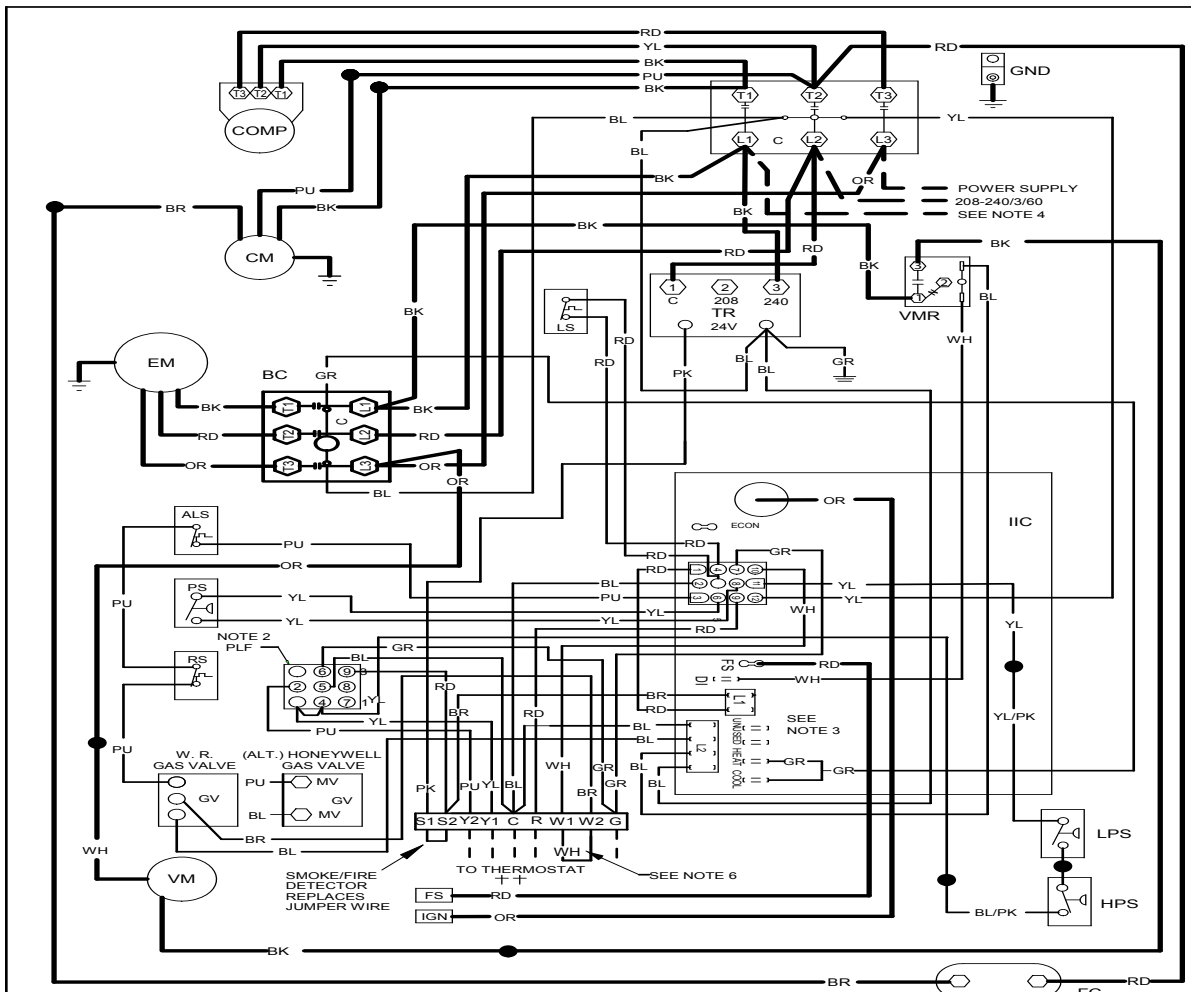

High Voltage: Disconnect all power before servicing or installing this unit. Multiple power sources may be present. Failure to do so may cause property damage, personal injury, or death.

WARNING

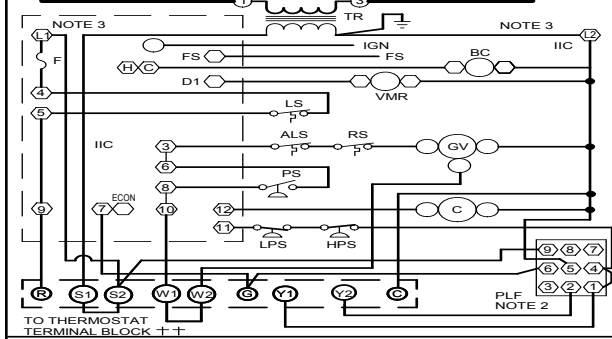
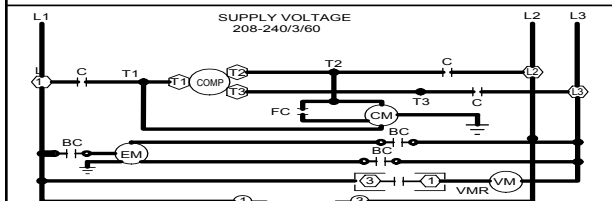

- COMPONENT LEGEND**
- ALS AUXILIARY LIMIT SWITCH
 - BC BLOWER CONTACTOR
 - COMP COMPRESSOR
 - CM CONDENSER MOTOR
 - C CONTACTOR
 - EM EVAPORATOR MOTOR
 - F FUSE
 - FC FAN CAPACITOR
 - FS FLAME SENSOR
 - GND EQUIPMENT GROUND
 - GV GAS VALVE
 - HPS HIGH PRESSURE SWITCH
 - IBR INDOOR BLOWER RELAY
 - IIC INTEGRATED IGNITION CONTROL
 - IGN IGNITOR
 - IIC INTEGRATED IGNITION CONTROL
 - LS LIMIT SWITCH
 - PLF FEMALE PLUG/CONNECTOR
 - PS PRESSURE SWITCH
 - RS ROLLOUT SWITCH
 - TB1 TERMINAL BLOCK (24V SIGNAL)
 - TR TRANSFORMER
 - VM VENT MOTOR
 - VMR VENT MOTOR RELAY

- FACTORY WIRING**
- LINE VOLTAGE
 - - - LOW VOLTAGE
 - OPTIONAL HIGH VOLTAGE
- FIELD WIRING**
- - - HIGH VOLTAGE
 - - - LOW VOLTAGE
- WIRE CODE**
- BK BLACK
 - BL BLUE
 - BR BROWN
 - GR GREEN
 - OR ORANGE
 - PK PINK
 - PU PURPLE
 - RD RED
 - WH WHITE
 - YL YELLOW
 - YL/PK BLUE WITH PINK STRIP
 - YL/PK YELLOW WITH PINK STRIP

- NOTES**
1. REPLACEMENT WIRE MUST BE THE SAME SIZE AND TYPE OF INSULATION AS ORIGINAL. (USE COPPER CONDUCTOR ONLY).
 2. ACCESSORY ECONOMIZER PLUG ADJACENT TO BLOWER HOUSING IN RETURN AIR COMPARTMENT. REMOVE MALE PLUG AND ATTACH FEMALE PLUG TO THE ECONOMIZER ACCESSORY.
 3. L1 AND L2 ON IIC CONTROL IS 24V INPUT.
 4. USE COPPER CONDUCTORS ONLY. ++ USE NEC CLASS 2 WIRE.
 5. FOR 208 VOLT TRANSFORMER OPERATION, MOVE BLACK WIRE FROM TERMINAL (3) TO TERMINAL (2) ON TRANSFORMER.
 6. FOR LOW STAGE OPERATION ONLY, REMOVE WHITE JUMPER. FOR 2 STAGE OPERATION, REMOVE JUMPER AND CONNECT W2 TO W2 ON THERMOSTAT.

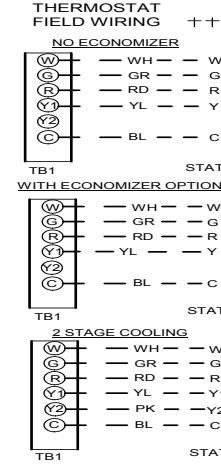

INSTALLER/SERVICEMAN

THE STATUS LIGHT ON THE FURNACE CONTROL MAY BE USED AS A GUIDE TO TROUBLESHOOTING THIS APPLIANCE. STATUS LIGHT CODES ARE AS FOLLOWS:

STATUS LIGHT	EQUIP. STATUS	CHECK
ON	NORMAL OPERATION	
OFF	NO POWER OR INTERNAL CONTROL	CHECK INPUT POWER CHECK FUSE ON CONTROL REPLACE CONTROL
1 BLINK	IGNITION FAILURE OPEN ROLLOUT SWITCH OPEN AUX. LIMIT SWITCH	GAS PRESSURE GAS VALVE FLAME SENSOR FLAME ROLLOUT BAD SWITCH AUX. LIMIT OPEN
2 BLINKS	PRESSURE SWITCH OPEN	CHECK PRESSURE SWITCH
3 BLINKS	PRESSURE SWITCH CLOSED WITHOUT INDUCER ON	CHECK PRESSURE SWITCH
4 BLINKS	OPEN LIMIT SWITCH	CHECK MAIN LIMIT OPEN
5 BLINKS	FALSE FLAME SENSED	STICKING GAS VALVE
6 BLINKS	COMPRESSOR OUTPUT DELAY	3 MIN. COMP ANTI-CYCLE TIMER

SEE UNIT RATING PLATE FOR TYPE AND SIZE OF OVER CURRENT PROTECTION

208-240/3/60 0140L02894-A

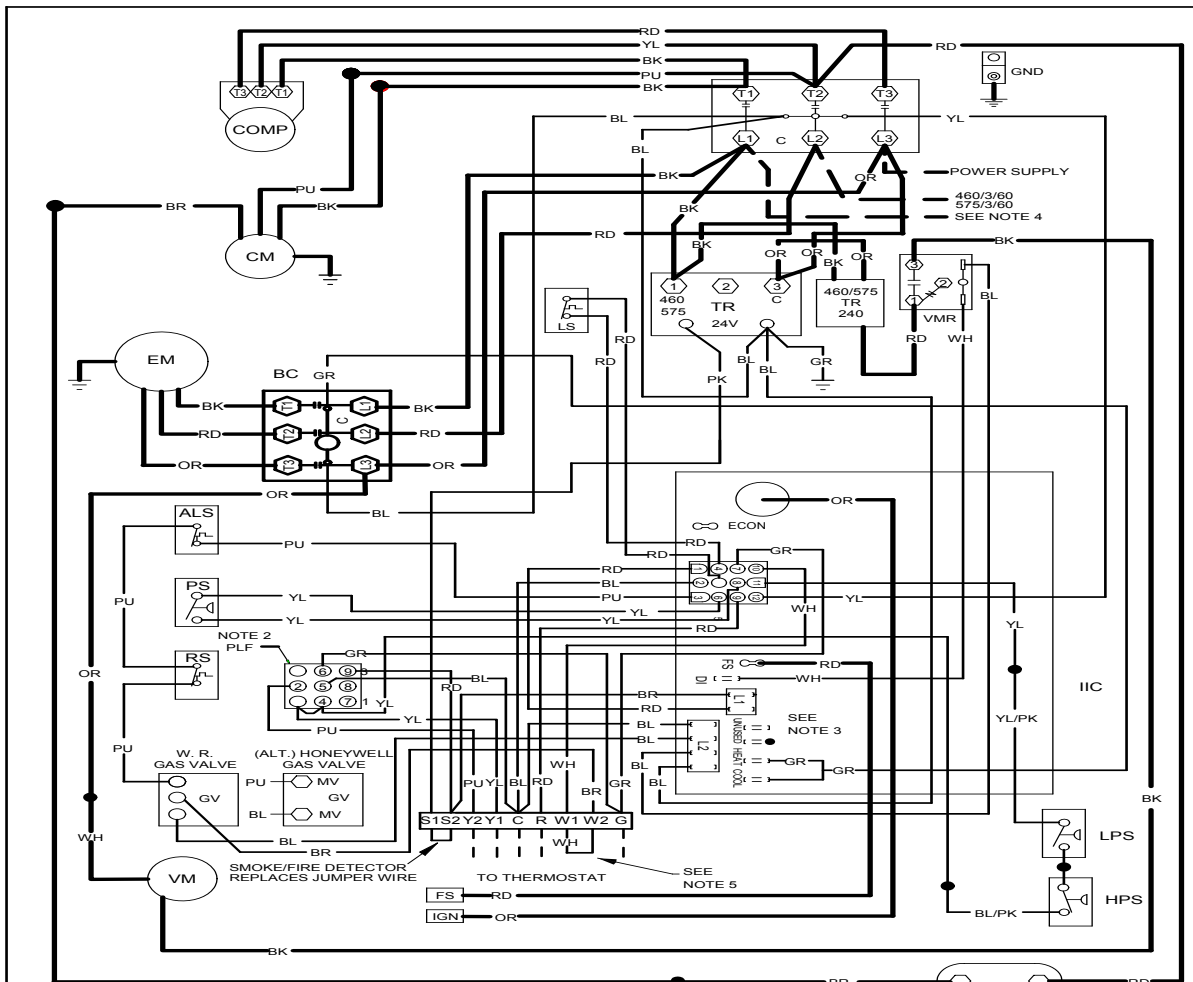

WARNING: Disconnect all power before servicing or installing this unit. Multiple power sources may be present. Failure to do so may cause property damage, personal injury, or death.

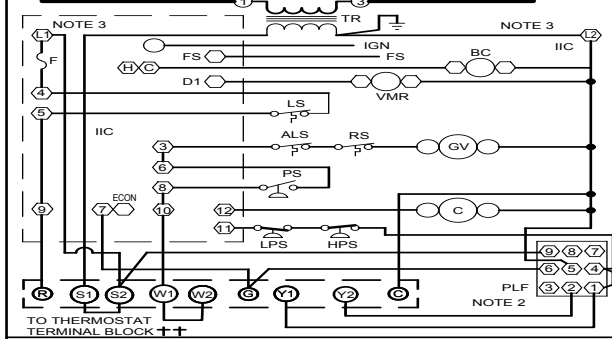
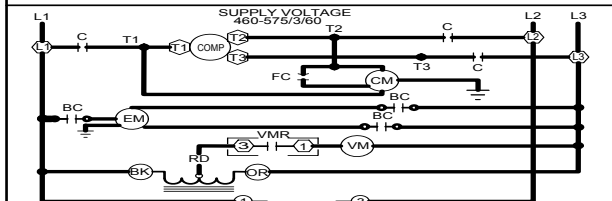

- COMPONENT LEGEND**
- ALS AUXILLARY LIMIT SWITCH
 - BC BLOWER CONTACTOR
 - COMP COMPRESSOR
 - CM CONDENSER MOTOR
 - C CONTACTOR
 - EM EVAPORATOR MOTOR
 - FC FAN CAPACITOR
 - FS FLAME SENSOR
 - GND EQUIPMENT GROUND
 - HPS HIGH PRESSURE SWITCH
 - IBR INDOOR BLOWER RELAY
 - IIC INTEGRATED IGNITION CONTROL
 - IGN IGNITOR
 - LS LIMIT SWITCH
 - PLF FEMALE PLUG/CONNECTOR
 - PS PRESSURE SWITCH
 - RS ROLLOUT SWITCH
 - TB1 TERMINAL BLOCK (24V SIGNAL)
 - TR TRANSFORMER
 - VM VENT MOTOR
 - VMR VENT MOTOR RELAY

- NOTES**
1. REPLACEMENT WIRE MUST BE THE SAME SIZE AND TYPE OF INSULATION AS ORIGINAL. (USE COPPER CONDUCTOR ONLY).
 2. ACCESSORY ECONOMIZER PLUG ADJACENT TO BLOWER HOUSING IN RETURN AIR COMPARTMENT. REMOVE MALE PLUG AND ATTACH FEMALE PLUG TO THE ECONOMIZER ACCESSORY.
 3. L1 AND L2 ON IIC CONTROL IS 24V INPUT.
 4. USE COPPER CONDUCTORS ONLY. + + USE NEC CLASS 2 WIRE.
 5. FOR LOW STAGE OPERATION ONLY, REMOVE WHITE JUMPER. FOR 2 STAGE OPERATION, REMOVE JUMPER AND CONNECT W2 TO W2 ON THERMOSTAT.

- FACTORY WIRING**
- LINE VOLTAGE
 - LOW VOLTAGE
 - OPTIONAL HIGH VOLTAGE
- FIELD WIRING**
- HIGH VOLTAGE
 - LOW VOLTAGE
- WIRE CODE**
- BK BLACK
 - BL BLUE
 - BR BROWN
 - GR GREEN
 - OR ORANGE
 - PK PINK
 - PU PURPLE
 - RD RED
 - WH WHITE
 - YL YELLOW
 - BL/PK BLUE WITH PINK STRIP
 - YL/PK YELLOW WITH PINK STRIP

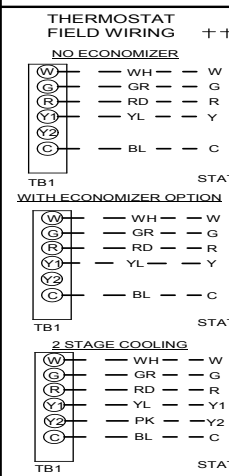

INSTALLER/SERVICEMAN

THE STATUS LIGHT ON THE FURNACE CONTROL MAY BE USED AS A GUIDE TO TROUBLESHOOTING THIS APPLIANCE. STATUS LIGHT CODES ARE AS FOLLOWS:

STATUS LIGHT	EQUIP. STATUS	CHECK
ON	NORMAL OPERATION	-
OFF	NO POWER OR INTERNAL CONTROL	CHECK INPUT POWER CHECK FUSE ON CONTROL REPLACE CONTROL
1 BLINK	IGNITION FAILURE OPEN ROLLOUT SWITCH OPEN AUX. LIMIT SWITCH	CHECK GAS FLOW GAS PRESSURE GAS VALVE FLAME SENSOR FLAME ROLLOUT BAD SWITCH AUX. LIMIT OPEN
2 BLINKS	PRESSURE SWITCH OPEN	CHECK PRESSURE SWITCH
3 BLINKS	PRESSURE SWITCH CLOSED WITHOUT INDUCER ON	CHECK PRESSURE SWITCH
4 BLINKS	OPEN LIMIT SWITCH FALSE FLAME	CHECK MAIN LIMIT OPEN BAD SWITCH
5 BLINKS	SENSING	STICKING GAS VALVE
6 BLINKS	COMPRESSOR OUTPUT DELAY	3 MIN. COMP ANTI-CYCLE TIMER

SEE UNIT RATING PLATE FOR TYPE AND SIZE OF OVER CURRENT PROTECTION.



460-575/3/60 0140L02895-A

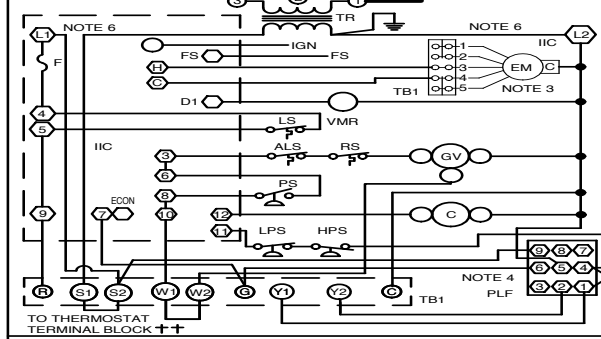
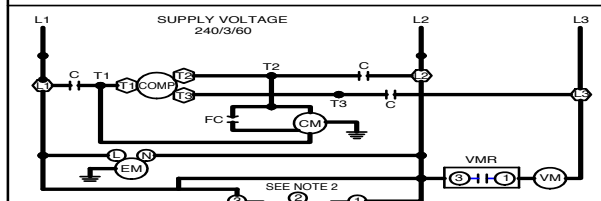
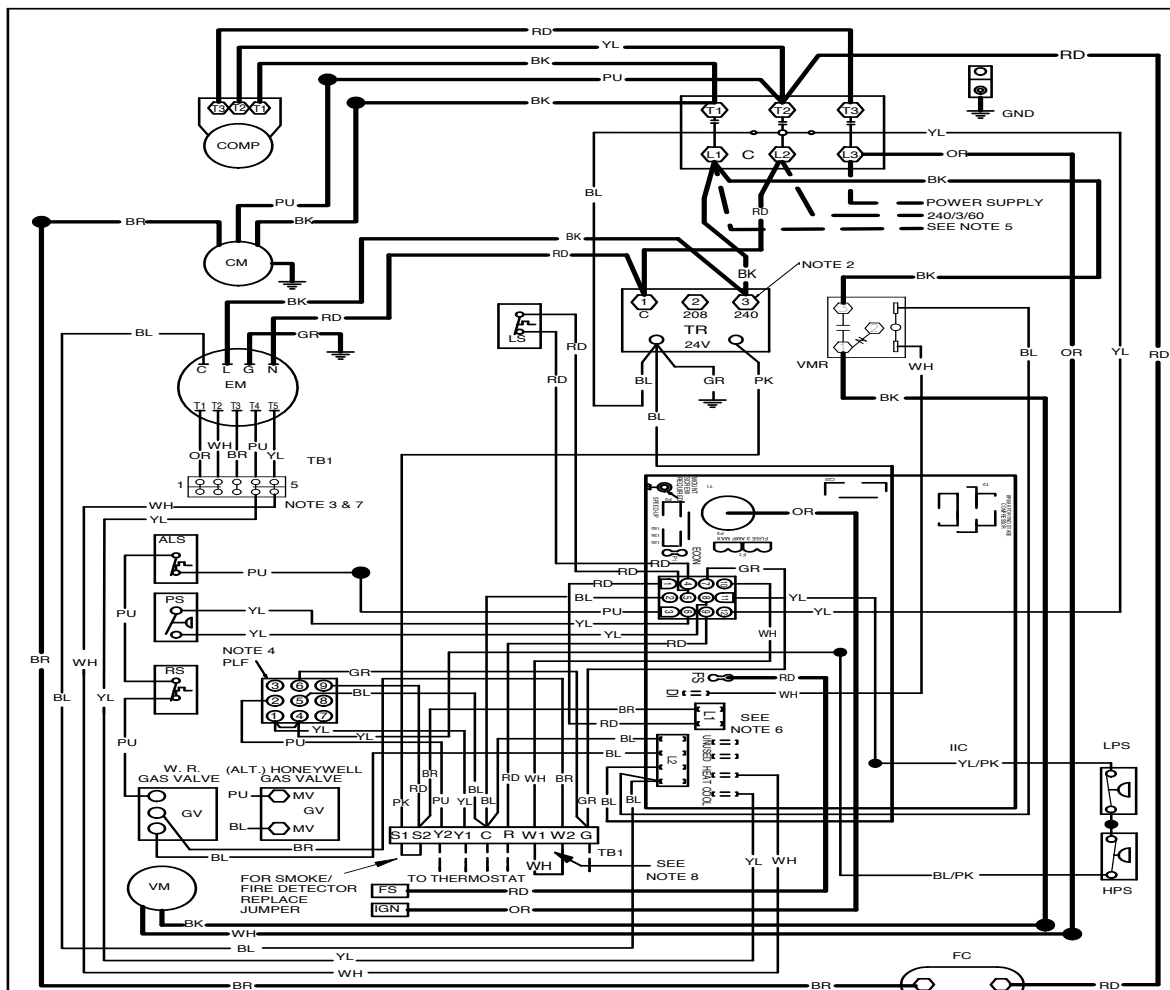

- COMPONENT LEGEND**
- ALS AUXILIARY LIMIT SWITCH
 - COMP COMPRESSOR
 - CM CONDENSER MOTOR
 - C CONTACTOR
 - EM EVAPORATOR MOTOR
 - F FUSE
 - FC FAN CAPACITOR
 - FS FLAME SENSOR
 - GND EQUIPMENT GROUND
 - GV GAS VALVE
 - HPS HIGH PRESSURE SWITCH
 - IIC INTEGRATED IGNITION CONTROL
 - IGN IGNITOR
 - LS LIMIT SWITCH
 - LPS LOW PRESSURE SWITCH
 - PLF FEMALE PLUG/CONNECTOR
 - PS PRESSURE SWITCH
 - RS ROLLOUT SWITCH
 - TB1 TERMINAL BLOCK (24V SIGNAL)
 - TR TRANSFORMER
 - VM VENT MOTOR
 - VMR VENT MOTOR RELAY

- NOTES**
1. REPLACE WIRE MUST BE THE SAME SIZE AND TYPE OF INSULATION AS ORIGINAL. (USE COPPER CONDUCTOR ONLY).
 2. FOR 208 VOLT TRANSFORMER OPERATION MOVE BLACK WIRES FROM TERMINAL ① TO TERMINAL ② ON TRANSFORMER.
 3. FOR DIFFERENT THAN FACTORY SPEED TAP, CHANGE COOLING SPEED AT MOTOR T3 AND T4 TERMINALS. CHANGE HEATING SPEED AT MOTOR T1, T2, AND T5 TERMINALS.
- COOLING SPEED (YELLOW WIRE)**
- T3 - LOW SPEED
 - T4 - HIGH SPEED
- HEATING SPEED (WHITE WIRE)**
- T1 - LOW SPEED (070)
 - T2 - MED. SPEED
 - T5 - HIGH SPEED (140)
4. ACCESSORY ECONOMIZER PLUG ADJACENT TO BLOWER HOUSING IN RETURN AIR COMPARTMENT. REMOVE MALE PLUG AND ATTACH FEMALE PLUG TO ECONOMIZER ACCESSORY.
 5. USE COPPER CONDUCTORS ONLY. **+** USE NEC CLASS 2 WIRE.
 6. L1 AND L2 ON ICC CONTROL IS 24V INPUT.
 7. SPEED TAP TERMINATIONS SHOWN ON DIAGRAM ARE REPRESENTATIVE, BUT ACTUAL FACTORY SETTINGS MAY BE DIFFERENT BASED ON THE HEATING VALUE OF THE UNIT.
 8. FOR LOW STAGE OPERATION ONLY, REMOVE WHITE JUMPER. FOR 2 STAGE OPERATION, REMOVE JUMPER AND CONNECT W2 TO W2 ON THERMOSTAT.

SEE UNIT RATING PLATE FOR TYPE AND SIZE OF OVER CURRENT PROTECTION

- FACTORY WIRING**
- LINE VOLTAGE
 - LOW VOLTAGE
- FIELD WIRING**
- - - HIGH VOLTAGE
 - - - LOW VOLTAGE
- WIRE CODE**
- BK BLACK
 - BL BLUE
 - BR BROWN
 - GR GREEN
 - OR ORANGE
 - PK PINK
 - PU PURPLE
 - RD RED
 - WH WHITE
 - YL YELLOW
 - BL/PK BLUE WITH PINK STRIP
 - YL/PK YELLOW WITH PINK STRIP

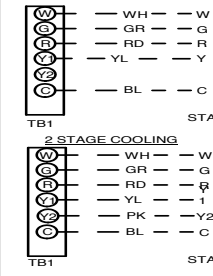
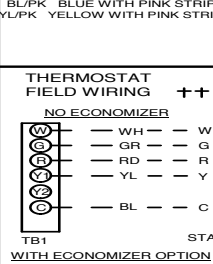

High Voltage: Disconnect all power before servicing or installing this unit. Multiple power sources may be present. Failure to do so may cause property damage, personal injury, or death.

WARNING

Wiring is subject to change. Always refer to the wiring diagram on the unit for the most up-to-date wiring.

WIRING DIAGRAM — DCG CONTROL DIAGRAM DCG072 - 2 SPEED (ALL VOLTAGES)

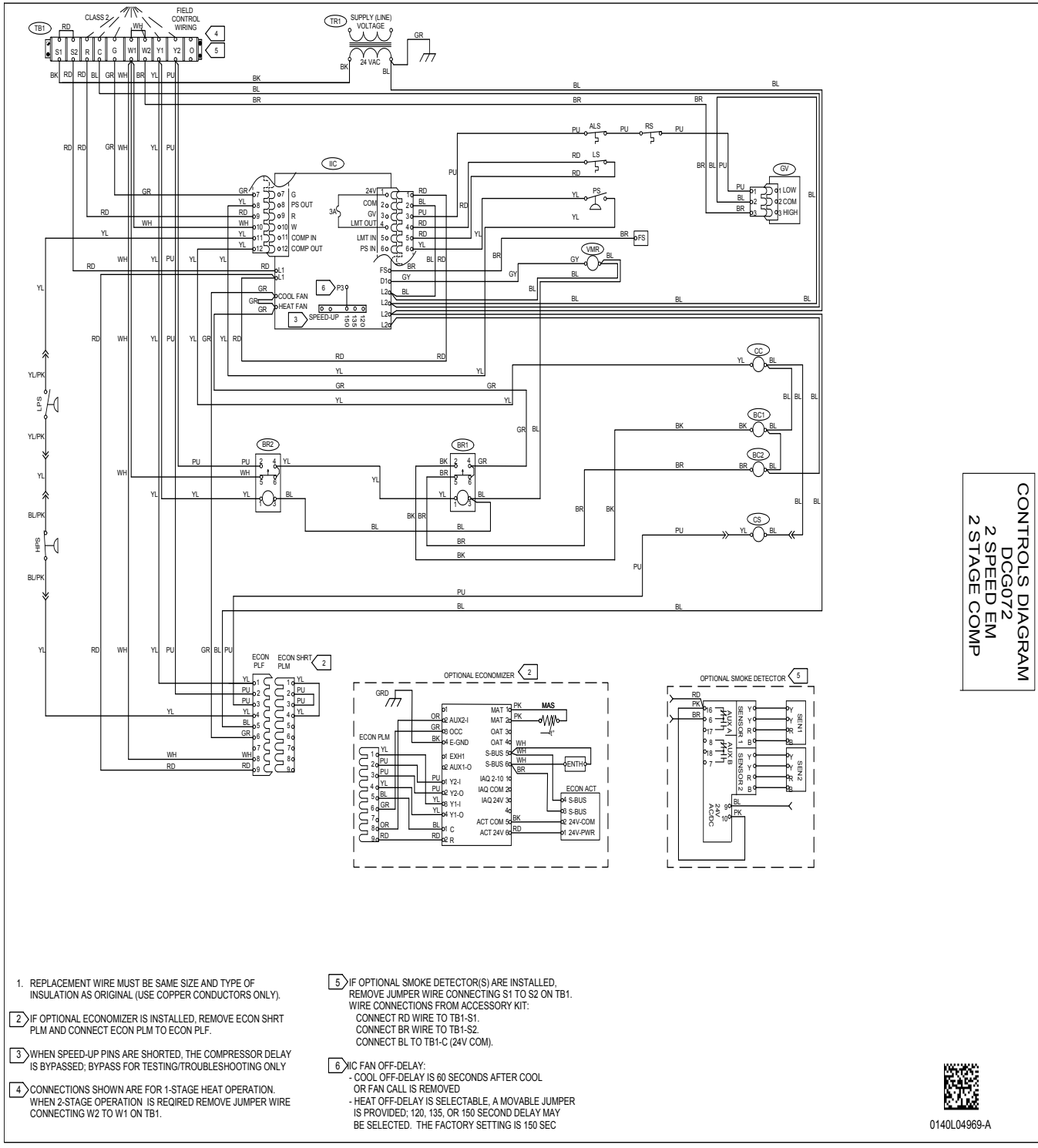

Wiring is subject to change. Always refer to the wiring diagram on the unit for the most up-to-date wiring.

WARNING **High Voltage:** Disconnect all power before servicing or installing this unit. Multiple power sources may be present. Failure to do so may cause property damage, personal injury, or death.

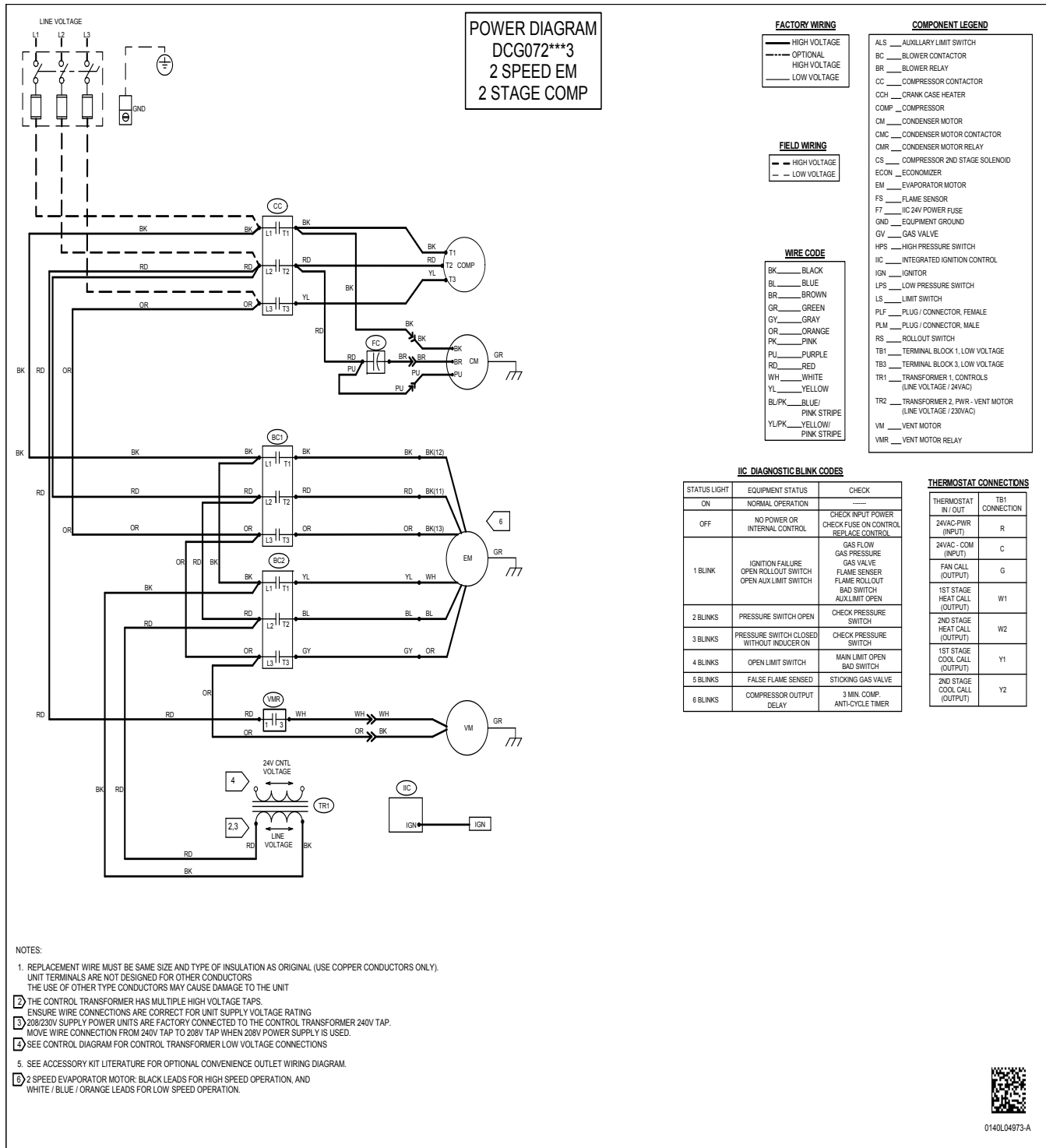

Wiring is subject to change. Always refer to the wiring diagram on the unit for the most up-to-date wiring.

WARNING

High Voltage: Disconnect all power before servicing or installing this unit. Multiple power sources may be present. Failure to do so may cause property damage, personal injury, or death.

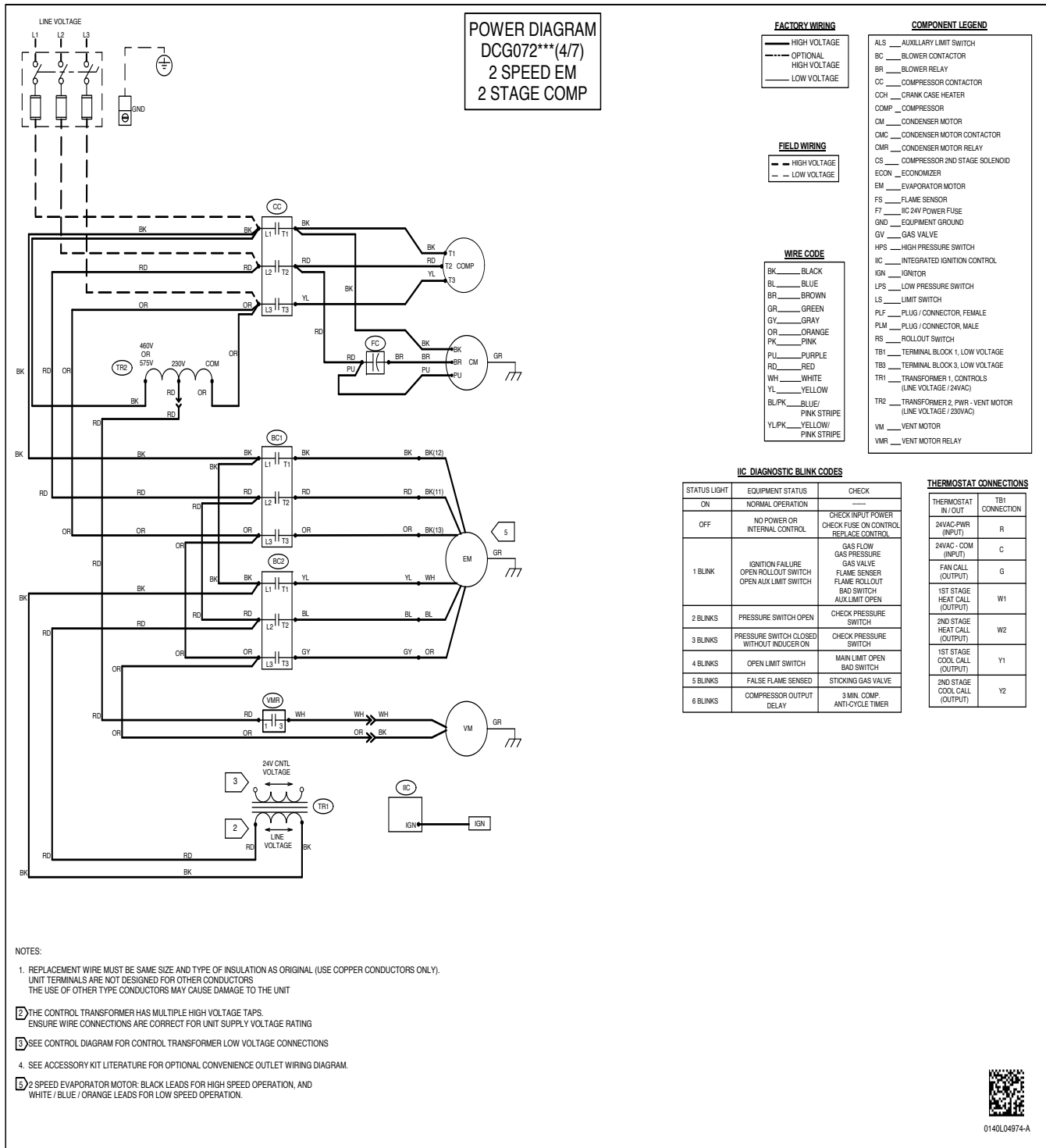

WIRING DIAGRAMS FOR MODELS WITH DDC CONTROLS

FOR COMPLETE INFORMATION AND INSTALLATION INSTRUCTIONS FOR MODELS
WITH DDC CONTROLS, SEE MANUAL DK-DDC-TGD-XXX

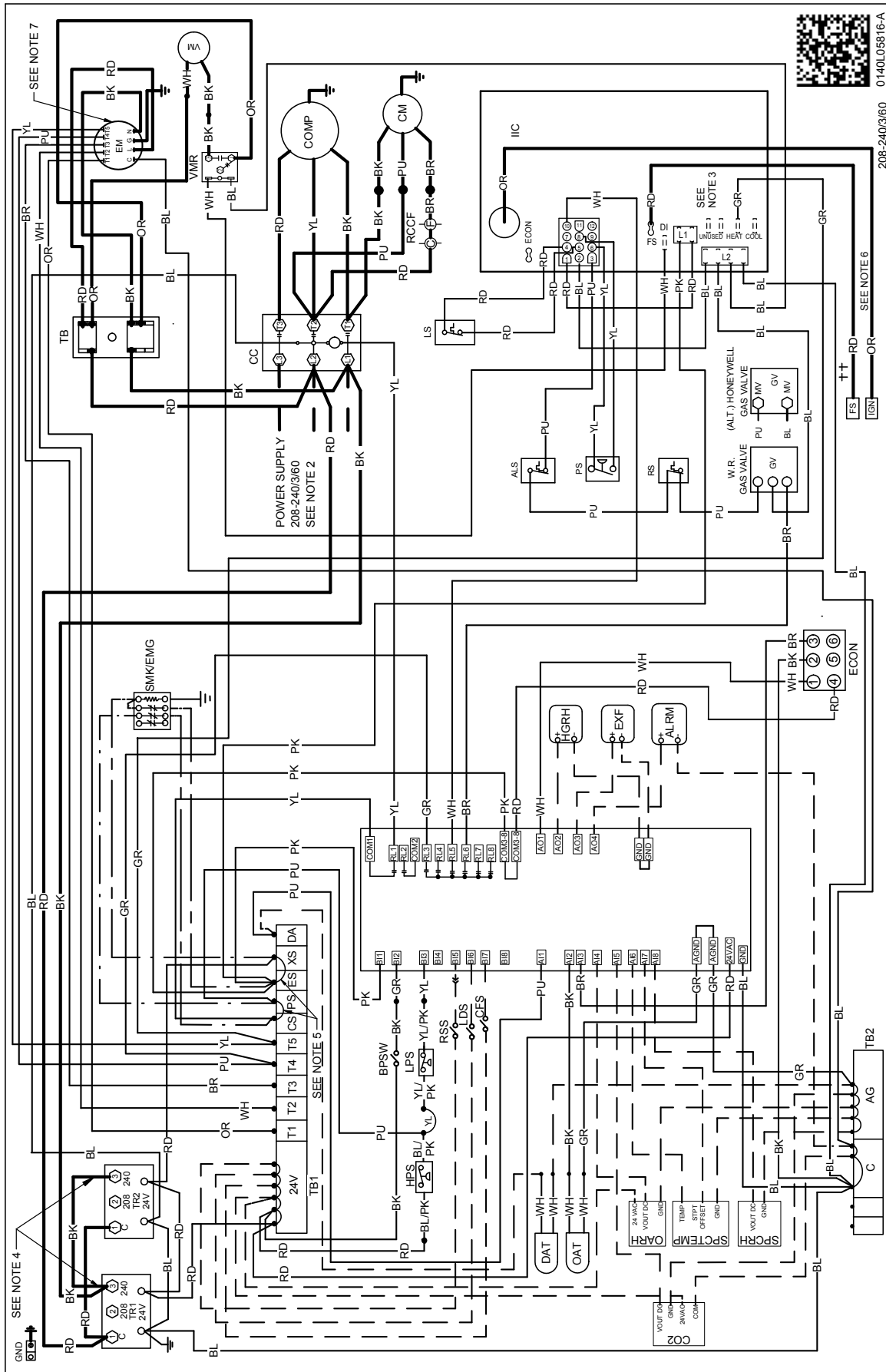

Wiring is subject to change. Always refer to the wiring diagram on the unit for the most up-to-date wiring.



High Voltage: Disconnect all power before servicing or installing this unit. Multiple power sources may be present. Failure to do so may cause property damage, personal injury, or death.

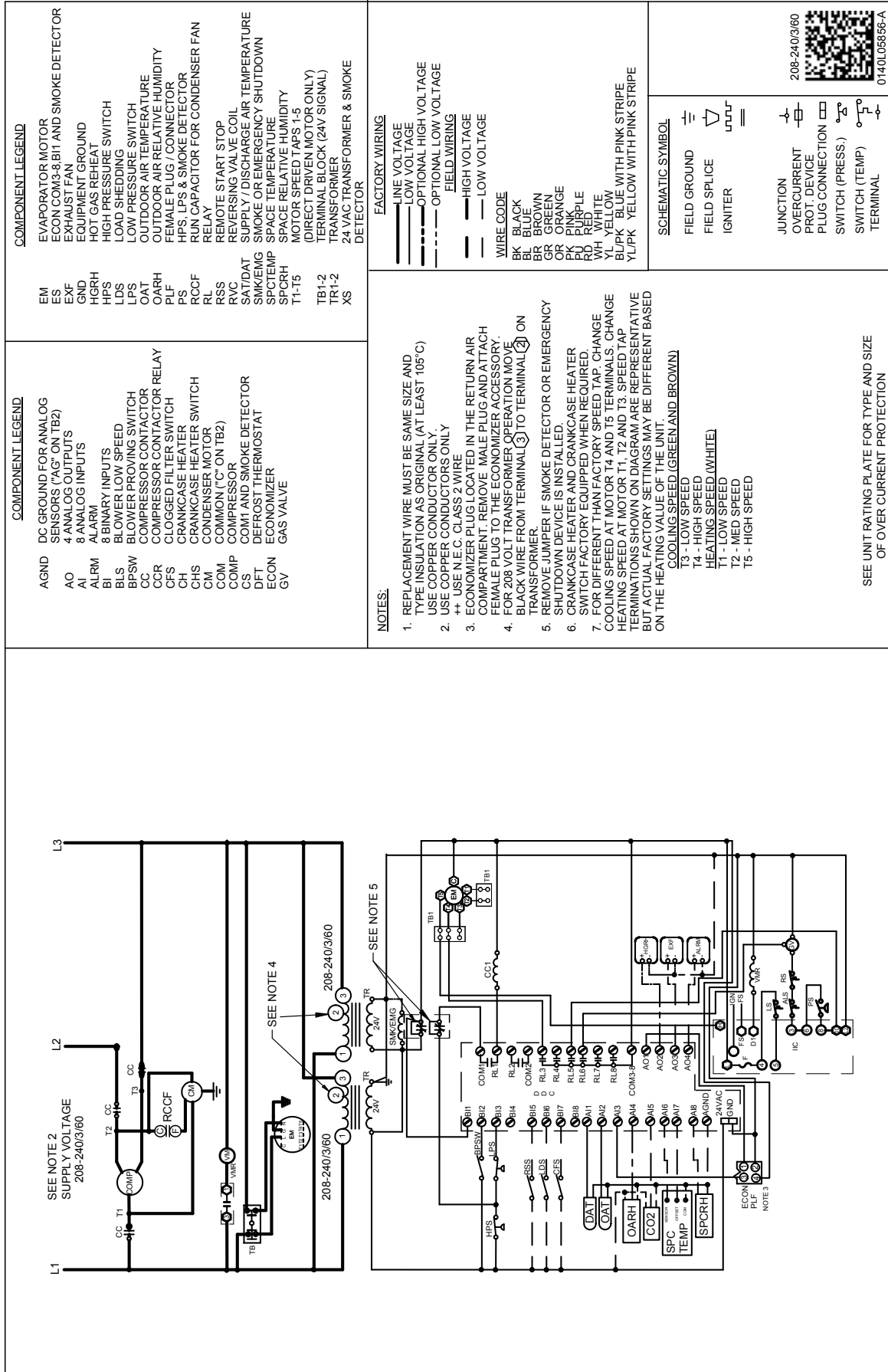

COMPONENT LEGEND

EM	EVAPORATOR MOTOR
ES	ECON COM3-B11 AND SMOKE DETECTOR
EXF	EXHAUST FAN
GND	EQUIPMENT GROUND
HGRH	HOT GAS REHEAT
HPS	HIGH PRESSURE SWITCH
LDS	LOAD SHEDDING
LPS	LOW PRESSURE SWITCH
OAT	OUTDOOR AIR TEMPERATURE
OARH	OUTDOOR AIR RELATIVE HUMIDITY
PLF	FEMALE PLUG / CONNECTOR
PS	HPS, LPS & SMOKE DETECTOR
RCCF	RUN CAPACITOR FOR CONDENSER FAN RELAY
RL	REMOTE START STOP
RSS	REVERSING VALVE COIL
RVC	SUPPLY / DISCHARGE AIR TEMPERATURE
SAT/DAT	SMOKE OR EMERGENCY SHUTDOWN
SMK/EMG	SPACE TEMPERATURE
SPCTEMP	SPACE RELATIVE HUMIDITY
SPCRH	MOTOR SPEED TAPS 1-5
T1-T5	(DIRECT DRIVEN MOTOR ONLY)
TB1-2	TERMINAL BLOCK (24V SIGNAL)
TR1-2	TRANSFORMER
XS	24 VAC TRANSFORMER & SMOKE DETECTOR

COMPONENT LEGEND

AGND	DC GROUND FOR ANALOG
AO	SENSORS ("AG" ON TB2)
AI	4 ANALOG OUTPUTS
BI	8 ANALOG INPUTS
ALRM	ALARM
BLS	8 BINARY INPUTS
BLSW	BLOWER LOW SPEED
CC	BLOWER PROTECT SWITCH
CCR	COMPRESSOR CONTACTOR
CFC	COMPRESSOR CONTACTOR RELAY
CH	CLOGGED FILTER SWITCH
CHS	CRANKCASE HEATER
CM	CRANKCASE HEATER SWITCH
COM	COMMON ("C" ON TB2)
COMP	COMPRESSOR
CS	COM1 AND SMOKE DETECTOR
DFT	DEFROST THERMOSTAT
ECON	ECONOMIZER
GV	GAS VALVE

- NOTES:**
- REPLACEMENT WIRE MUST BE SAME SIZE AND TYPE INSULATION AS ORIGINAL (AT LEAST 105°C) USE COPPER CONDUCTOR ONLY.
 - USE COPPER CONDUCTORS ONLY.
 - USE N.E.C. CLASS 2 WIRE.
 - ECONOMIZER PLUG LOCATED IN THE RETURN AIR COMPARTMENT; REMOVE MALE PLUG AND ATTACH FEMALE PLUG TO THE ECONOMIZER ACCESSORY.
 - FOR 208 VOLT TRANSFORMER OPERATION MOVE BLACK WIRE FROM TERMINAL (3) TO TERMINAL (2) ON TRANSFORMER.
 - REMOVE JUMPER IF SMOKE DETECTOR OR EMERGENCY SHUTDOWN DEVICE IS INSTALLED.
 - CRANKCASE HEATER AND CRANKCASE HEATER SWITCH FACTORY EQUIPPED WHEN REQUIRED.
 - FOR DIFFERENT THAN FACTORY SPEED TAP, CHANGE COOLING SPEED AT MOTOR T4 AND T5 TERMINALS. CHANGE HEATING SPEED AT MOTOR T1, T2 AND T3. SPEED TAP TERMINATIONS SHOWN ON DIAGRAM ARE REPRESENTATIVE BUT ACTUAL FACTORY SETTINGS MAY BE DIFFERENT BASED ON THE HEATING VALUE OF THE UNIT.

- FACTORY WIRING**
- LINE VOLTAGE
 - LOW VOLTAGE
 - OPTIONAL HIGH VOLTAGE
 - OPTIONAL LOW VOLTAGE
 - FIELD WIRING
 - HIGH VOLTAGE
 - LOW VOLTAGE
- WIRE CODE**
- BK BLACK
 - BL BLUE
 - BR BROWN
 - GR GREEN
 - OR ORANGE
 - PK PINK/STRIPE
 - RD RED
 - WH WHITE
 - YL YELLOW
 - BL/PK BLUE WITH PINK STRIPE
 - YL/PK YELLOW WITH PINK STRIPE
- SCHEMATIC SYMBOL**
- FIELD GROUND
 - FIELD SPLICE
 - IGNITER
 - JUNCTION
 - OVERCURRENT
 - PROT. DEVICE
 - PLUG CONNECTION
 - SWITCH (PRESS.)
 - SWITCH (TEMP)
 - TERMINAL

SEE UNIT RATING PLATE FOR TYPE AND SIZE OF OVER CURRENT PROTECTION

208-240/3/60

208-240/3/60

208-240/3/60

208-240/3/60

208-240/3/60

208-240/3/60

208-240/3/60

208-240/3/60

208-240/3/60

208-240/3/60

208-240/3/60

208-240/3/60

208-240/3/60

208-240/3/60

208-240/3/60

208-240/3/60

208-240/3/60

208-240/3/60

Wiring is subject to change. Always refer to the wiring diagram on the unit for the most up-to-date wiring.

WARNING

High Voltage: Disconnect all power before servicing or installing this unit. Multiple power sources may be present. Failure to do so may cause property damage, personal injury, or death.

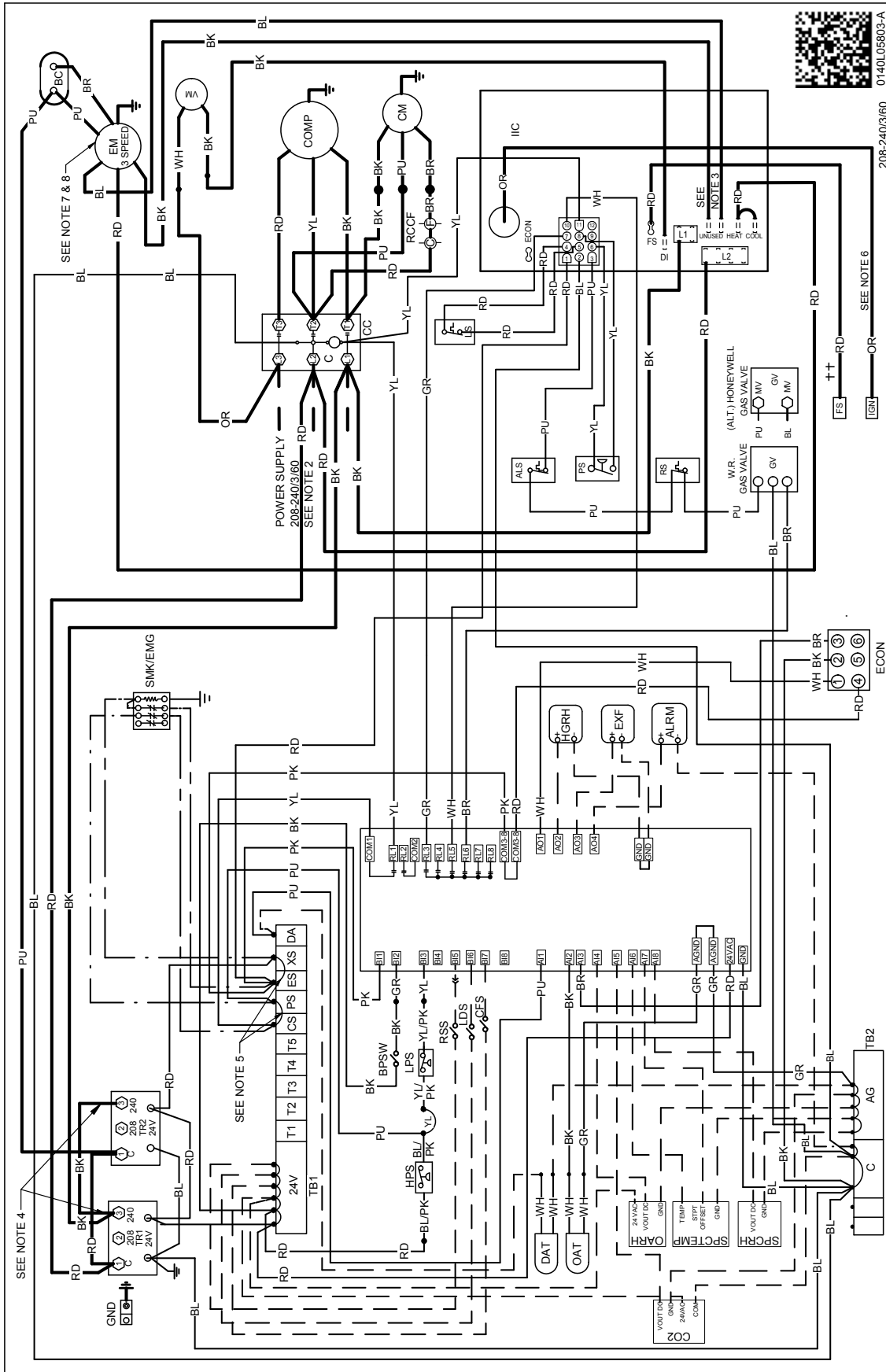

Wiring is subject to change. Always refer to the wiring diagram on the unit for the most up-to-date wiring.



WARNING

High Voltage: Disconnect all power before servicing or installing this unit. Multiple power sources may be present. Failure to do so may cause property damage, personal injury, or death.

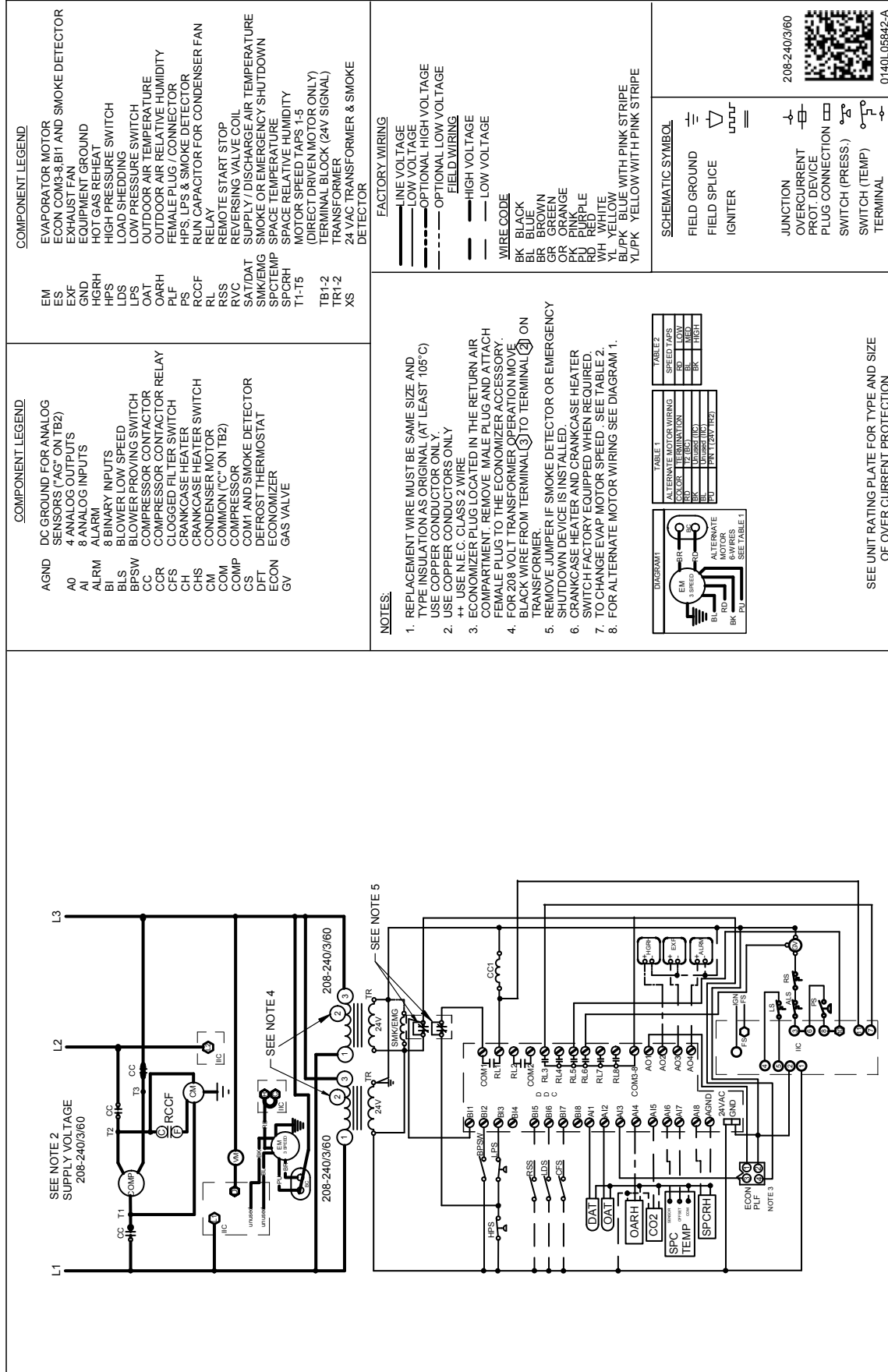

COMPONENT LEGEND

EM	EVAPORATOR MOTOR
ES	ECON COM3-8/B11 AND SMOKE DETECTOR
EXF	EXHAUST FAN
GND	EQUIPMENT GROUND
HGRH	HOT GAS REHEAT
HPS	HIGH PRESSURE SWITCH
LDS	LOAD SHEDDING
LPS	LOW PRESSURE SWITCH
OAT	OUTDOOR AIR TEMPERATURE
OARH	OUTDOOR AIR RELATIVE HUMIDITY
PLF	FEMALE PLUG / CONNECTOR
PS	HPS, LPS & SMOKE DETECTOR
RCCF	RUN CAPACITOR FOR CONDENSER FAN
RL	RELAY
RSS	REMOTE START STOP
RVC	REVERSING VALVE COIL
SAT/DAT	SUPPLY / DISCHARGE AIR TEMPERATURE
SMK/ENG	SMOKE OR EMERGENCY SHUTDOWN
SPCTEMP	SPACE TEMPERATURE
SPCRH	SPACE RELATIVE HUMIDITY
T1-T5	MOTOR SPEED TAPS 1-5
TB1-2	(DIRECT DRIVEN MOTOR ONLY)
TR1-2	TERMINAL BLOCK (24V SIGNAL)
XS	24 VAC TRANSFORMER & SMOKE DETECTOR

COMPONENT LEGEND

AGND	DC GROUND FOR ANALOG
A0	SENSORS ("AG" ON TB2)
AI	4 ANALOG OUTPUTS
ALRM	8 ANALOG INPUTS
BI	8 BINARY INPUTS
BLS	BLOWER LOW SPEED
BPSW	BLOWER PROVING SWITCH
CC	COMPRESSOR CONTACTOR
CCR	COMPRESSOR CONTACTOR RELAY
CFS	CLOGGED FILTER SWITCH
CH	CRANKCASE HEATER
CHS	CRANKCASE HEATER SWITCH
CM	CONDENSER MOTOR
COM	COMMON ("C" ON TB2)
COMP	COMPRESSOR
COM1	COM1 AND SMOKE DETECTOR
DFT	DEFROST THERMOSTAT
ECON	ECONOMIZER
GV	GAS VALVE

FACTORY WIRING

—	LINE VOLTAGE
—	LOW VOLTAGE
—	OPTIONAL HIGH VOLTAGE
—	OPTIONAL LOW VOLTAGE
—	FIELD WIRING
—	HIGH VOLTAGE
—	LOW VOLTAGE

WIRE CODE

BK	BLACK
BL	BLUE
BR	BROWN
GR	GREEN
PK	PINK
PU	PURPLE
RD	RED
WH	WHITE
YL	YELLOW
BL/PK	BLACK WITH PINK STRIPE
YL/PK	YELLOW WITH PINK STRIPE

NOTES:

- REPLACEMENT WIRE MUST BE SAME SIZE AND TYPE INSULATION AS ORIGINAL (AT LEAST 105°C) USE COPPER CONDUCTOR ONLY.
- USE COPPER CONDUCTORS ONLY.
- ECONOMIZER PLUG LOCATED IN THE RETURN AIR COMPARTMENT. REMOVE MALE PLUG AND ATTACH FEMALE PLUG TO THE ECONOMIZER ACCESSORY.
- FOR 208 VOLT TRANSFORMER OPERATION MOVE BLACK WIRE FROM TERMINAL ② TO TERMINAL ① ON TRANSFORMER.
- REMOVE JUMPER IF SMOKE DETECTOR OR EMERGENCY SHUTDOWN DEVICE IS INSTALLED.
- CRANKCASE HEATER AND CRANKCASE HEATER SWITCH FACTORY EQUIPPED WHEN REQUIRED.
- TO CHANGE EVAP MOTOR SPEED SEE TABLE 2.
- FOR ALTERNATE MOTOR WIRING SEE DIAGRAM 1.

SCHEMATIC SYMBOL

—	FIELD GROUND
—	FIELD SPICE
—	IGNITER
—	JUNCTION
—	OVERCURRENT
—	PROT. DEVICE
—	PLUG CONNECTION
—	SWITCH (PRESS.)
—	SWITCH (TEMP)
—	TERMINAL

208-240/3/60

0140L05842-A

DIAGRAM 1

ALTERNATE MOTOR WIRING	
COLOR	TERMINATION
RED	LOW
BK	MEDIA (T02)
BL	UNUSE (T03)
WH	PLT (T04-T05)

TABLE 2

SPEED TAPS	
RED	LOW
BK	MEDIA
WH	HIGH

SEE UNIT RATING PLATE FOR TYPE AND SIZE OF OVER CURRENT PROTECTION

WARNING

High Voltage: Disconnect all power before servicing or installing this unit. Multiple power sources may be present. Failure to do so may cause property damage, personal injury, or death.

Wiring is subject to change. Always refer to the wiring diagram on the unit for the most up-to-date wiring.

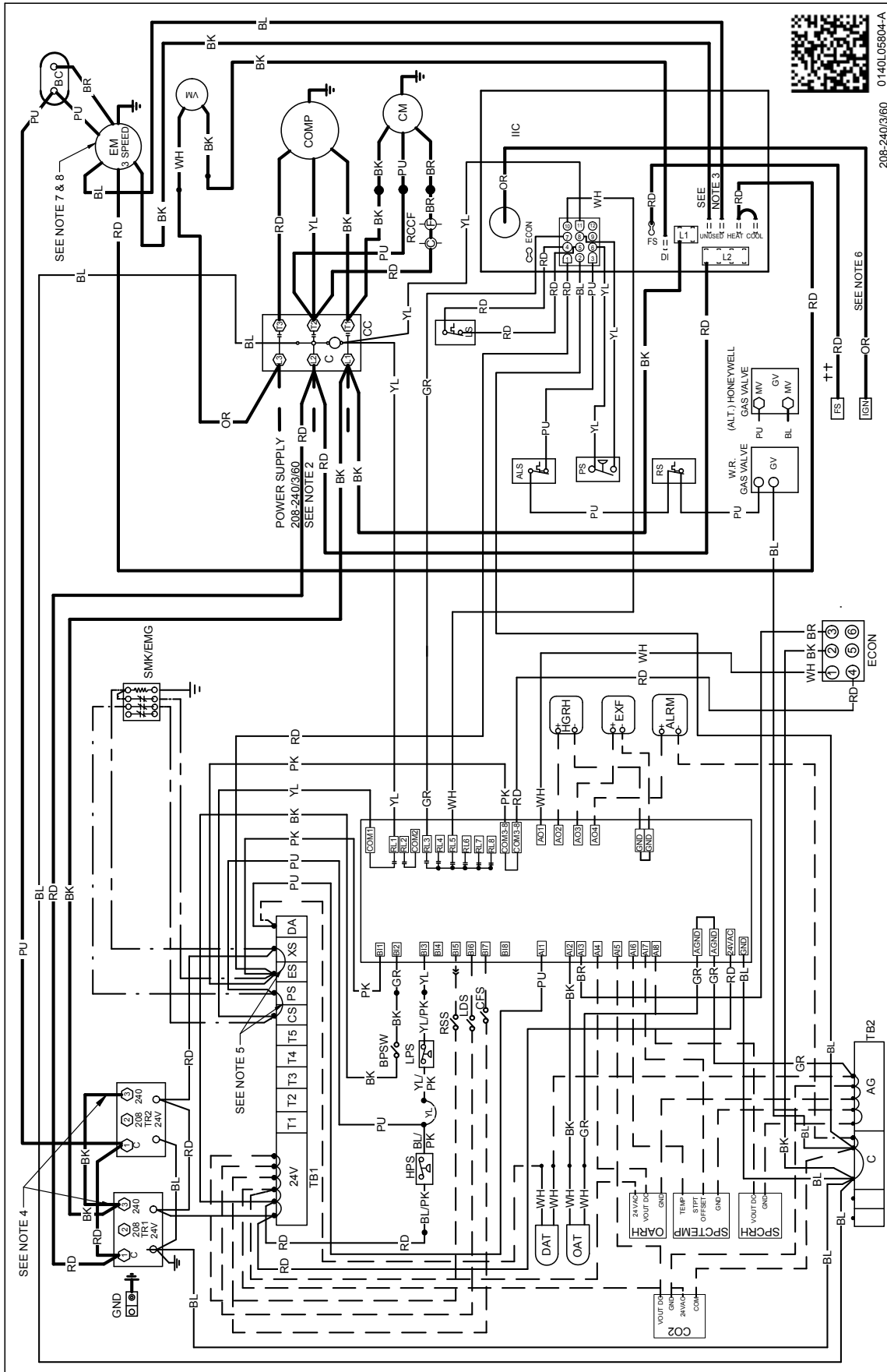

208-240/3/60 0140L05804-A



High Voltage: Disconnect all power before servicing or installing this unit. Multiple power sources may be present. Failure to do so may cause property damage, personal injury, or death.



WARNING

Wiring is subject to change. Always refer to the wiring diagram on the unit for the most up-to-date wiring.

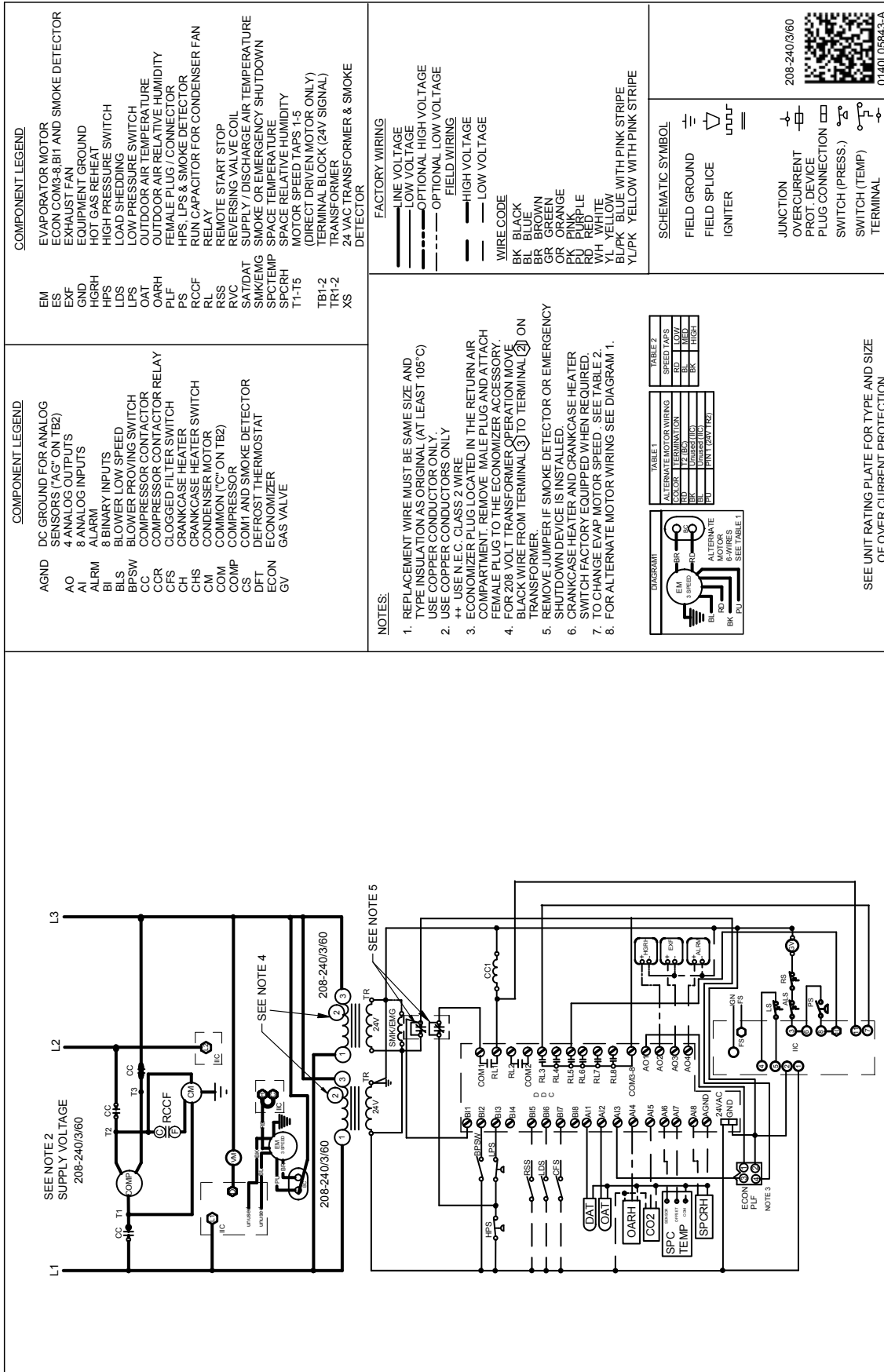

COMPONENT LEGEND

- AGND DC GROUND FOR ANALOG
 AO 4 ANALOG OUTPUTS
 AI 8 ANALOG INPUTS
 ALRM ALARM
 BI 8 BINARY INPUTS
 BLS BLOWER LOW SPEED
 BPSW BLOWER PROVING SWITCH
 CCR COMPRESSOR CONTACTOR
 CFS CLOGGED FILTER SWITCH
 CHS CRANKCASE HEATER
 CM CONDENSER MOTOR
 COM COMMON ("C"-ON TB2)
 COMP COMPRESSOR
 CS COM1 AND SMOKE DETECTOR
 DFT DEFROST THERMOSTAT
 ECON ECONOMIZER
 GV GAS VALVE

COMPONENT LEGEND

- EVAPORATOR MOTOR
 ECON COM3-8, BI AND SMOKE DETECTOR
 EXHAUST FAN
 EQUIPMENT GROUND
 HOT GAS REHEAT
 HIGH PRESSURE SWITCH
 LOW PRESSURE SWITCH
 OUTDOOR AIR TEMPERATURE
 OUTDOOR AIR RELATIVE HUMIDITY
 FEMALE PLUG / CONNECTOR
 HPS, LPS & SMOKE DETECTOR
 RUN CAPACITOR FOR CONDENSER FAN RELAY
 REMOTE START STOP
 REVERSING VALVE COIL
 SUPPLY / DISCHARGE AIR TEMPERATURE
 SMOKE OR EMERGENCY SHUTDOWN
 SPACE TEMPERATURE
 SPACE RELATIVE HUMIDITY
 MOTOR SPEED TAPS 1-5
 (DIRECT DRIVEN MOTOR ONLY)
 TERMINAL BLOCK (24V SIGNAL)
 TRANSFORMER
 24 VAC TRANSFORMER & SMOKE DETECTOR

NOTES:

- REPLACEMENT WIRE MUST BE SAME SIZE AND TYPE INSULATION AS ORIGINAL (AT LEAST 105°C) USE COPPER CONDUCTORS ONLY.
- USE COPPER CONDUCTORS ONLY.
- ECONOMIZER PLUG LOCATED IN THE RETURN AIR COMPARTMENT; REMOVE MALE PLUG AND ATTACH FEMALE PLUG TO THE ECONOMIZER ACCESSORY.
- FOR 208 VOLT TRANSFORMER OPERATION MOVE BLACK WIRE FROM TERMINAL (3) TO TERMINAL (2) ON TRANSFORMER.
- REMOVE JUMPER IF SMOKE DETECTOR OR EMERGENCY SHUTDOWN DEVICE IS INSTALLED.
- CRANKCASE HEATER AND CRANKCASE HEATER SWITCH FACTORY EQUIPPED WHEN REQUIRED.
- TO CHANGE EVAP MOTOR SPEED - SEE TABLE 2.
- FOR ALTERNATE MOTOR WIRING SEE DIAGRAM 1.

FACTORY WIRING

- LINE VOLTAGE
- LOW VOLTAGE
- OPTIONAL HIGH VOLTAGE
- OPTIONAL LOW VOLTAGE
- FIELD WIRING
- HIGH VOLTAGE
- LOW VOLTAGE

- WIRE CODE**
 BK BLACK
 BL BLUE
 BR BROWN
 GR GREEN
 OR ORANGE
 PU PURPLE
 RD RED
 WH WHITE
 YL YELLOW
 YL/PK YELLOW WITH PINK STRIPE

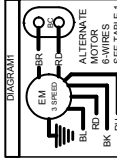

TABLE 1		TABLE 2	
ALTERNATE MOTOR WIRING		SPEED TAPS	
COLOR	TERMINAL	RD	LOW
BK	UNDESIGNATED	PU	MED
PU	UNDESIGNATED	RD	HI
RD	UNDESIGNATED	WH	
WH	UNDESIGNATED	YL	
YL	UNDESIGNATED	YL/PK	
YL/PK	UNDESIGNATED		

TABLE 1		TABLE 2	
ALTERNATE MOTOR WIRING		SPEED TAPS	
COLOR	TERMINAL	RD	LOW
BK	UNDESIGNATED	PU	MED
PU	UNDESIGNATED	RD	HI
RD	UNDESIGNATED	WH	
WH	UNDESIGNATED	YL	
YL	UNDESIGNATED	YL/PK	
YL/PK	UNDESIGNATED		

SEE UNIT RATING PLATE FOR TYPE AND SIZE OF OVER CURRENT PROTECTION



Wiring is subject to change. Always refer to the wiring diagram on the unit for the most up-to-date wiring.

WARNING
High Voltage: Disconnect all power before servicing or installing this unit. Multiple power sources may be present. Failure to do so may cause property damage, personal injury, or death.

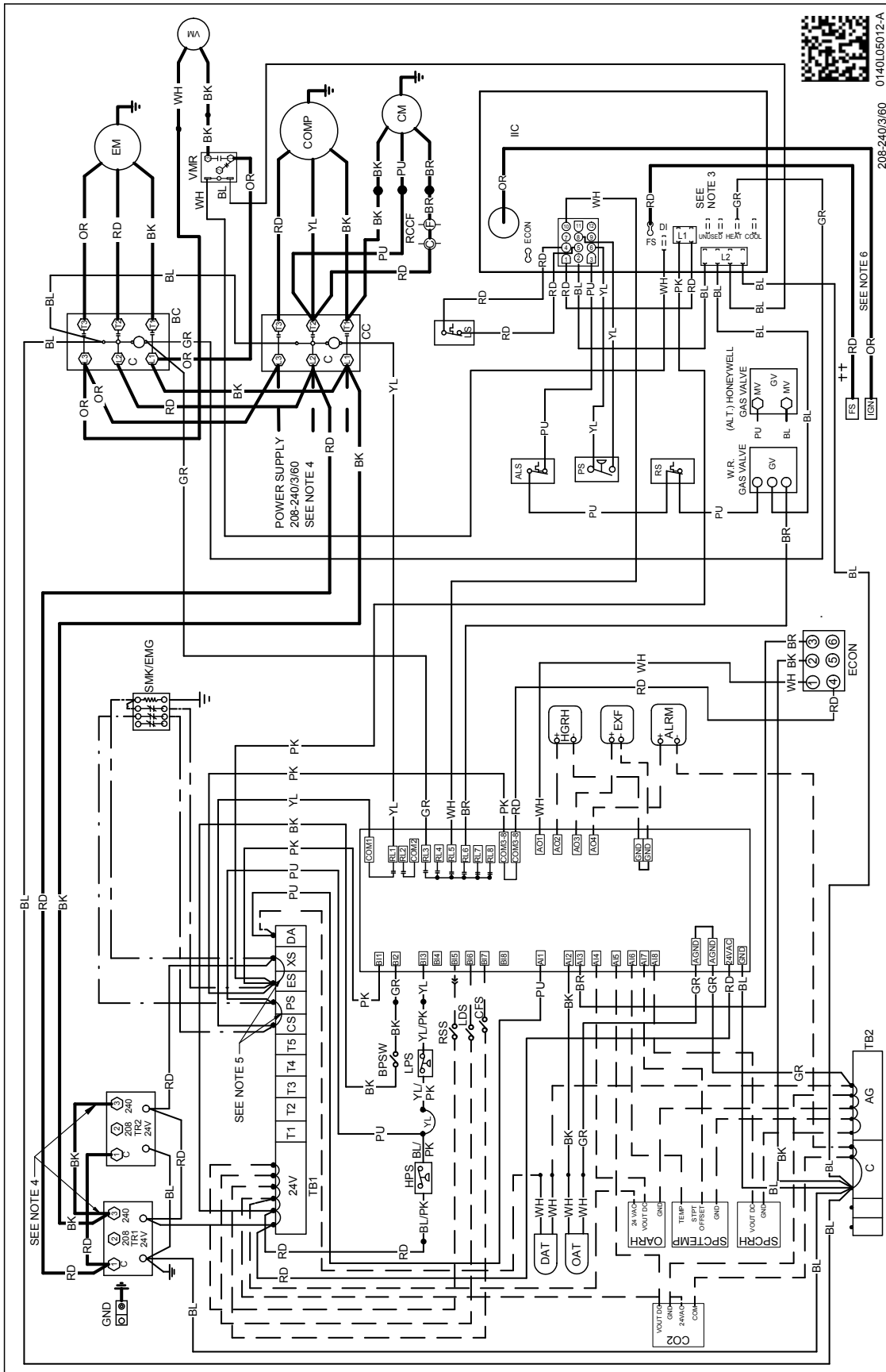

0140L05012-A

208-240/3/60

SEE NOTE 6

SEE NOTE 3

SEE NOTE 5

SEE NOTE 4

SEE NOTE 6

SEE NOTE 6

SEE NOTE 6

SEE NOTE 6

SEE NOTE 6

SEE NOTE 6

SEE NOTE 6

SEE NOTE 6

SEE NOTE 6

SEE NOTE 6

SEE NOTE 6

WARNING

High Voltage: Disconnect all power before servicing or installing this unit. Multiple power sources may be present. Failure to do so may cause property damage, personal injury, or death.

Wiring is subject to change. Always refer to the wiring diagram on the unit for the most up-to-date wiring.

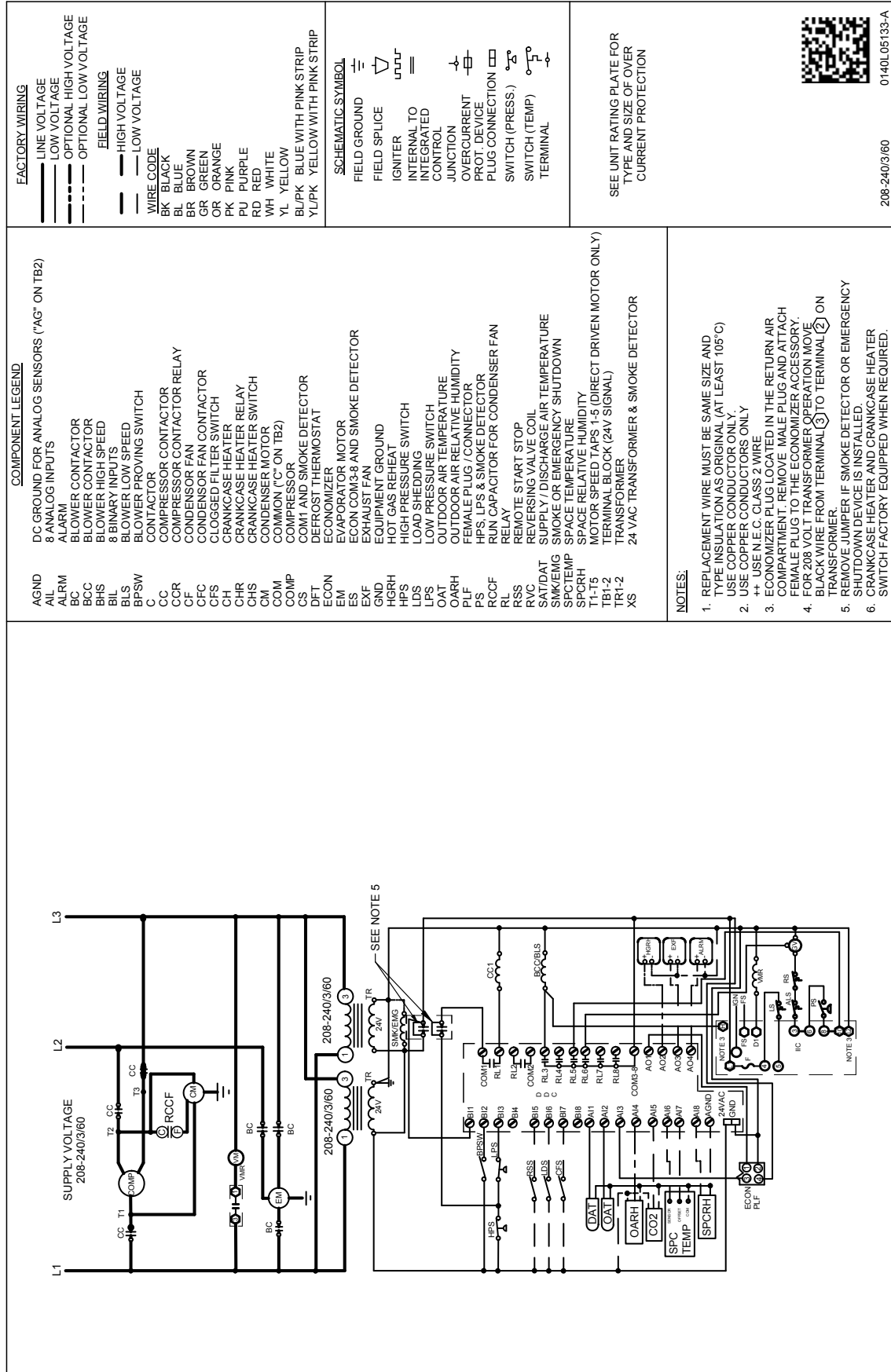

COMPONENT LEGEND

- DC GROUND FOR ANALOG SENSORS ("AG" ON TB2)
 8 ANALOG INPUTS
 ALARM
 BLOWER CONTACTOR
 BLOWER CONTACTOR
 BLOWER HIGH SPEED
 8 BINARY INPUTS
 BLOWER LOW SPEED
 BLOWER PROVING SWITCH
 CONTACTOR
 COMPRESSOR CONTACTOR
 COMPRESSOR CONTACTOR RELAY
 CONDENSOR FAN
 CONDENSOR FAN CONTACTOR
 CLOGGED FILTER SWITCH
 CRANKCASE HEATER
 CRANKCASE HEATER RELAY
 CRANKCASE HEATER SWITCH
 CONDENSER MOTOR
 COMMON "C" ON TB2)
 COMPRESSOR
 COM1 AND SMOKE DETECTOR
 DEFROST THERMOSTAT
 ECONOMIZER
 EVAPORATOR MOTOR
 ECON COM3-8 AND SMOKE DETECTOR
 EXHAUST FAN
 EQUIPMENT GROUND
 HOT GAS REHEAT
 HIGH PRESSURE SWITCH
 LOAD SHEDDING
 LOW PRESSURE SWITCH
 OUTDOOR AIR TEMPERATURE
 OUTDOOR AIR RELATIVE HUMIDITY
 FEMALE PLUG /CONNECTOR
 HPS, LPS & SMOKE DETECTOR
 RUN CAPACITOR FOR CONDENSER FAN RELAY
 RSS
 REMOTE START STOP
 REVERSING VALVE COIL
 RVC
 SUPPLY /DISCHARGE AIR TEMPERATURE
 SMOKE OR EMERGENCY SHUTDOWN
 SNK/EMG
 SPACE TEMPERATURE
 SPC/TEMP
 SPCRH
 SPACE RELATIVE HUMIDITY
 T1-T5
 MOTOR SPEED TAPS 1:5 (DIRECT DRIVEN MOTOR ONLY)
 TERMINAL BLOCK (24V SIGNAL)
 TRANSFORMER
 TR1-2
 TR1-2
 X5
 24 VAC TRANSFORMER & SMOKE DETECTOR

FACTORY WIRING

- LINE VOLTAGE
 LOW VOLTAGE
 OPTIONAL HIGH VOLTAGE
 OPTIONAL LOW VOLTAGE
FIELD WIRING
 HIGH VOLTAGE
 LOW VOLTAGE
WIRE CODE
 BK BLACK
 BL BLUE
 BR BROWN
 GR GREEN
 OR ORANGE
 PK PINK
 PU PURPLE
 RD RED
 WH WHITE
 YL YELLOW
 BL/PK BLUE WITH PINK STRIP
 YL/PK YELLOW WITH PINK STRIP

SCHEMATIC SYMBOL

- FIELD GROUND
 FIELD SPLICE
 IGNITER
 INTERNAL TO INTEGRATED CONTROL
 JUNCTION
 OVERCURRENT PROT. DEVICE
 PLUG CONNECTION
 SWITCH (PRESS.)
 SWITCH (TEMP)
 TERMINAL

SEE UNIT RATING PLATE FOR TYPE AND SIZE OF OVER CURRENT PROTECTION



208-240/3/60 0140L05133-A

NOTES:

1. REPLACEMENT WIRE MUST BE SAME SIZE AND TYPE INSULATION AS ORIGINAL (AT LEAST 105°C) USE COPPER CONDUCTORS ONLY
2. USE COPPER CONDUCTORS ONLY
3. ++ USE N.E.C. CLASS 2 WIRE
4. ECONOMIZER PLUG LOCATED IN THE RETURN AIR COMPARTMENT. REMOVE MALE PLUG AND ATTACH FEMALE PLUG TO THE ECONOMIZER ACCESSORY.
5. FOR 208 VOLT TRANSFORMER OPERATION MOVE BLACK WIRE FROM TERMINAL ② TO TERMINAL ① ON TRANSFORMER
6. REMOVE JUMPER IF SMOKE DETECTOR OR EMERGENCY SHUTDOWN DEVICE IS INSTALLED
7. CRANKCASE HEATER AND CRANKCASE HEATER SWITCH FACTORY EQUIPPED WHEN REQUIRED.

Wiring is subject to change. Always refer to the wiring diagram on the unit for the most up-to-date wiring.



High Voltage: Disconnect all power before servicing or installing this unit. Multiple power sources may be present. Failure to do so may cause property damage, personal injury, or death.

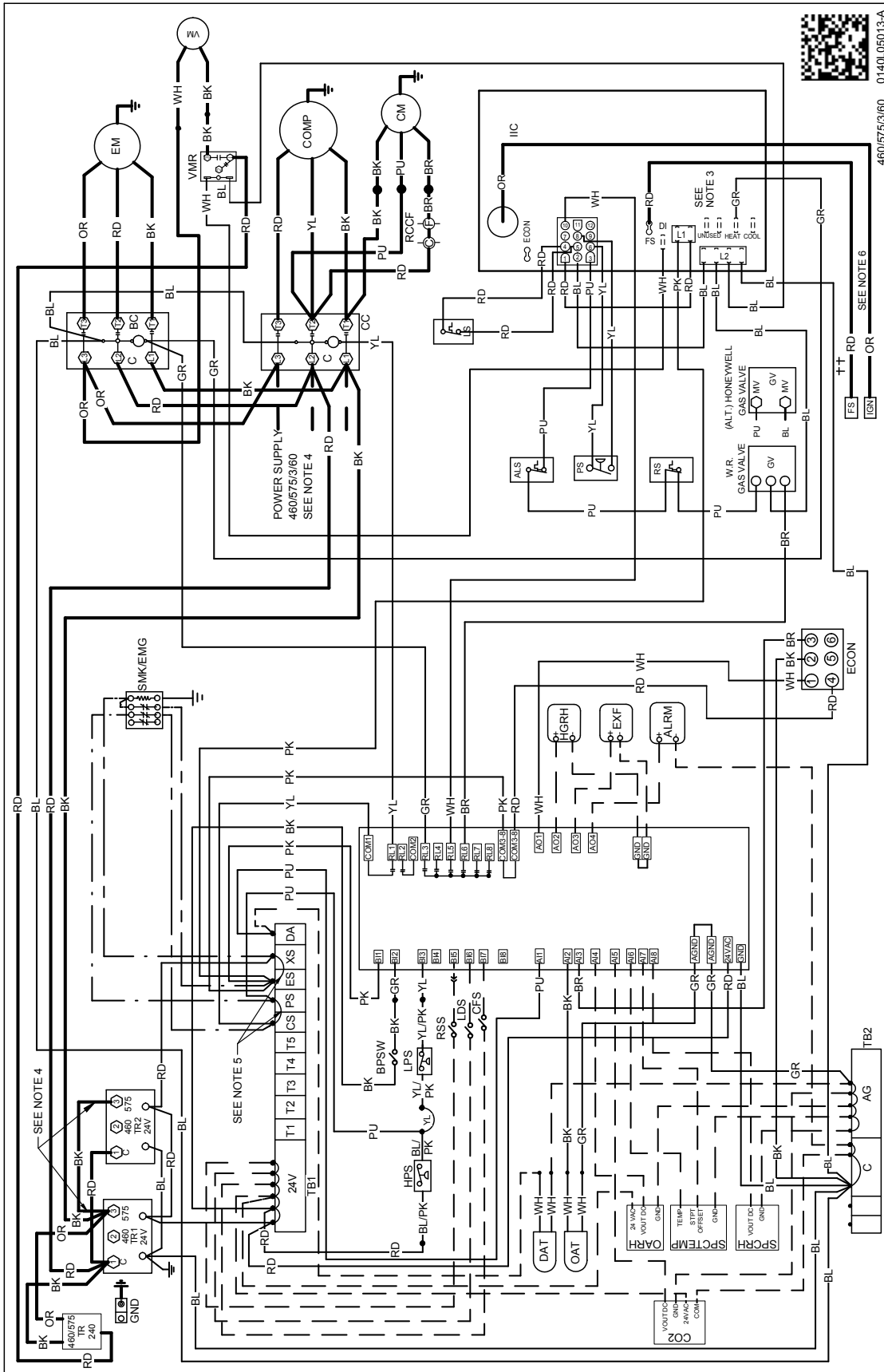

0140L06013A

460/575/3/60

SEE NOTE 6



High Voltage: Disconnect all power before servicing or installing this unit. Multiple power sources may be present. Failure to do so may cause property damage, personal injury, or death.

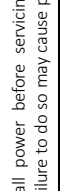

WARNING

Wiring is subject to change. Always refer to the wiring diagram on the unit for the most up-to-date wiring.

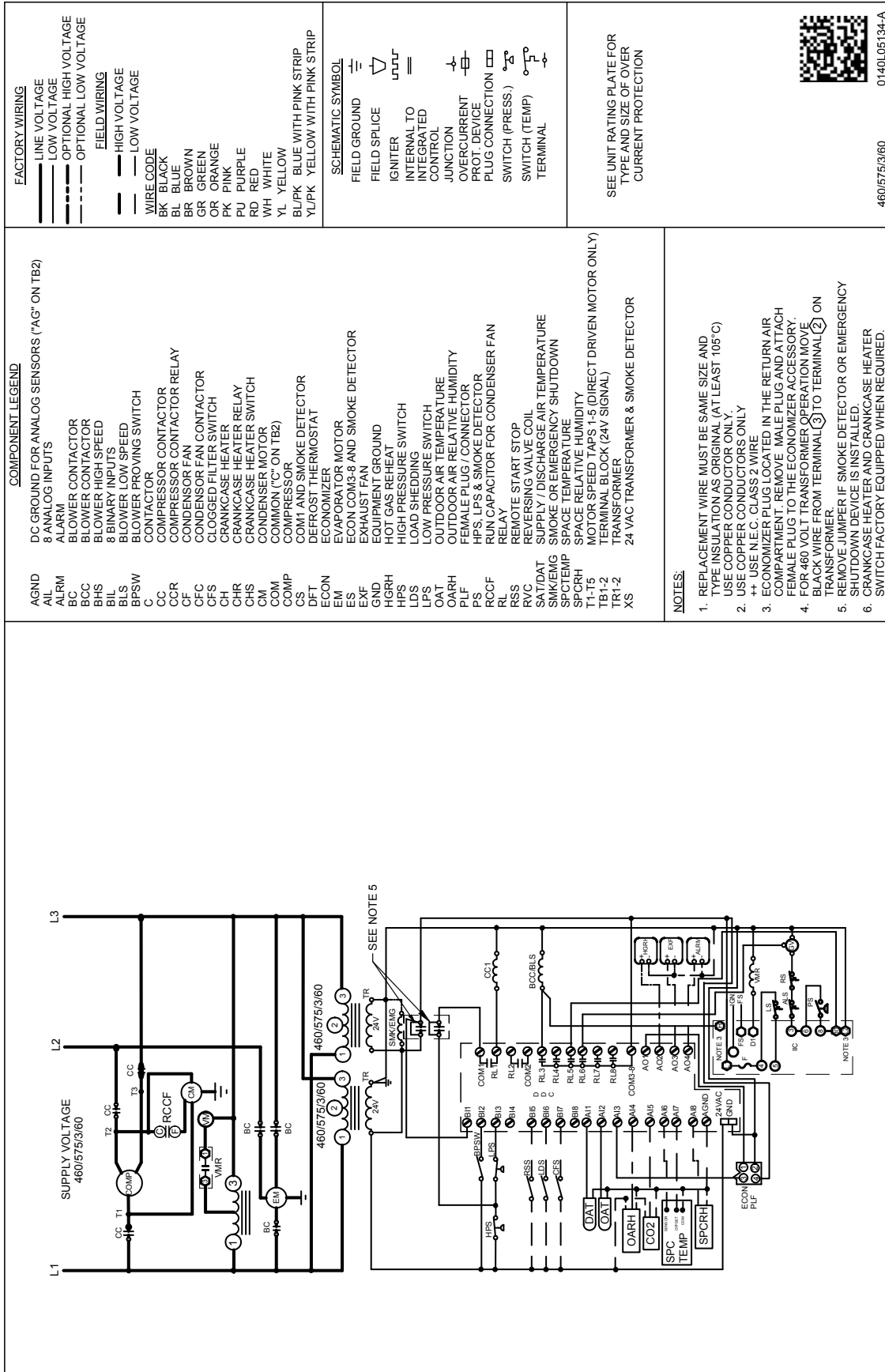

WARNING

High Voltage: Disconnect all power before servicing or installing this unit. Multiple power sources may be present. Failure to do so may cause property damage, personal injury, or death.

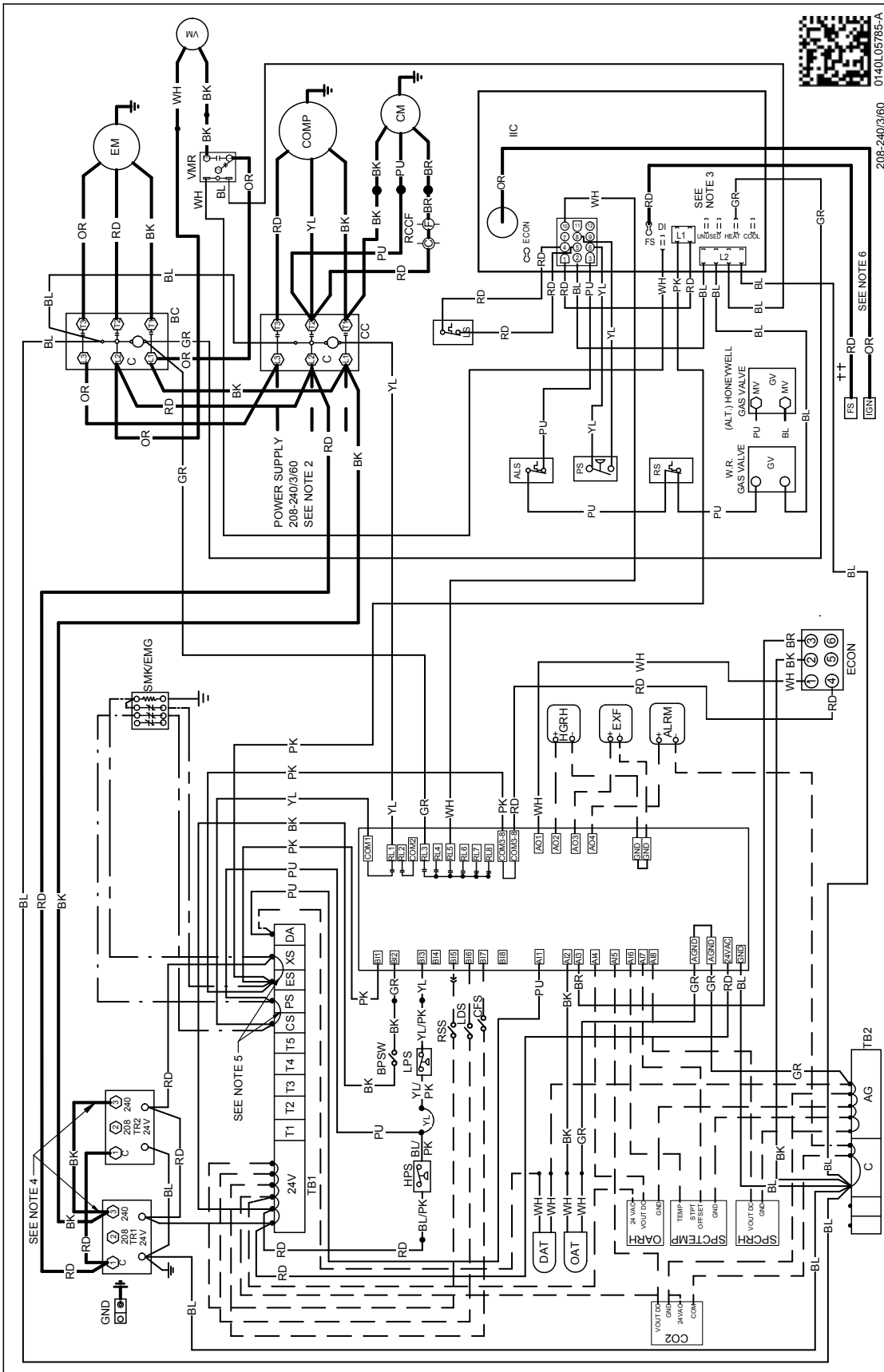

Wiring is subject to change. Always refer to the wiring diagram on the unit for the most up-to-date wiring.

WARNING

High Voltage: Disconnect all power before servicing or installing this unit. Multiple power sources may be present. Failure to do so may cause property damage, personal injury, or death.

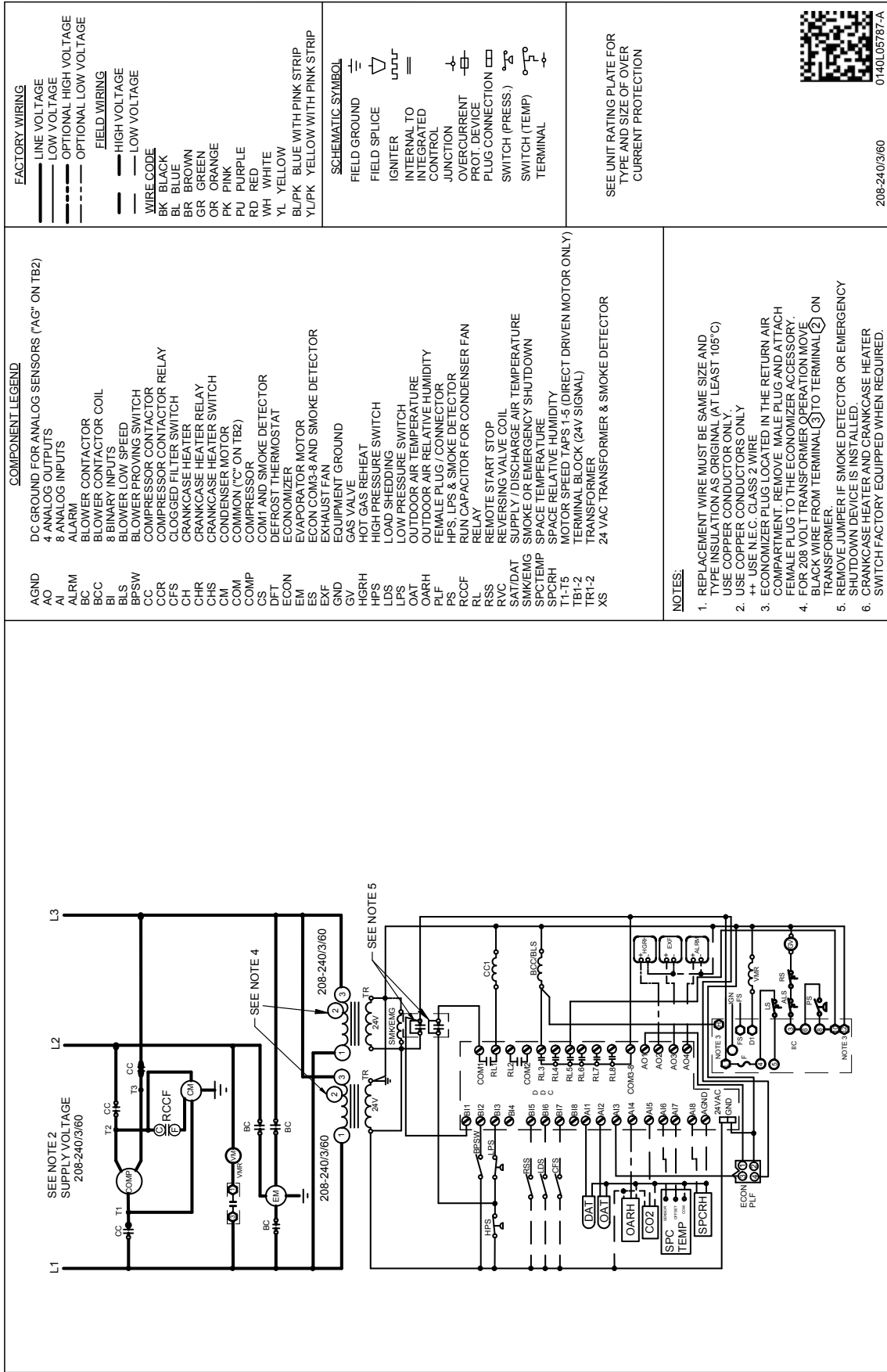

208-240/3/60
 0140L05787-A



WARNING

High Voltage: Disconnect all power before servicing or installing this unit. Multiple power sources may be present. Failure to do so may cause property damage, personal injury, or death.

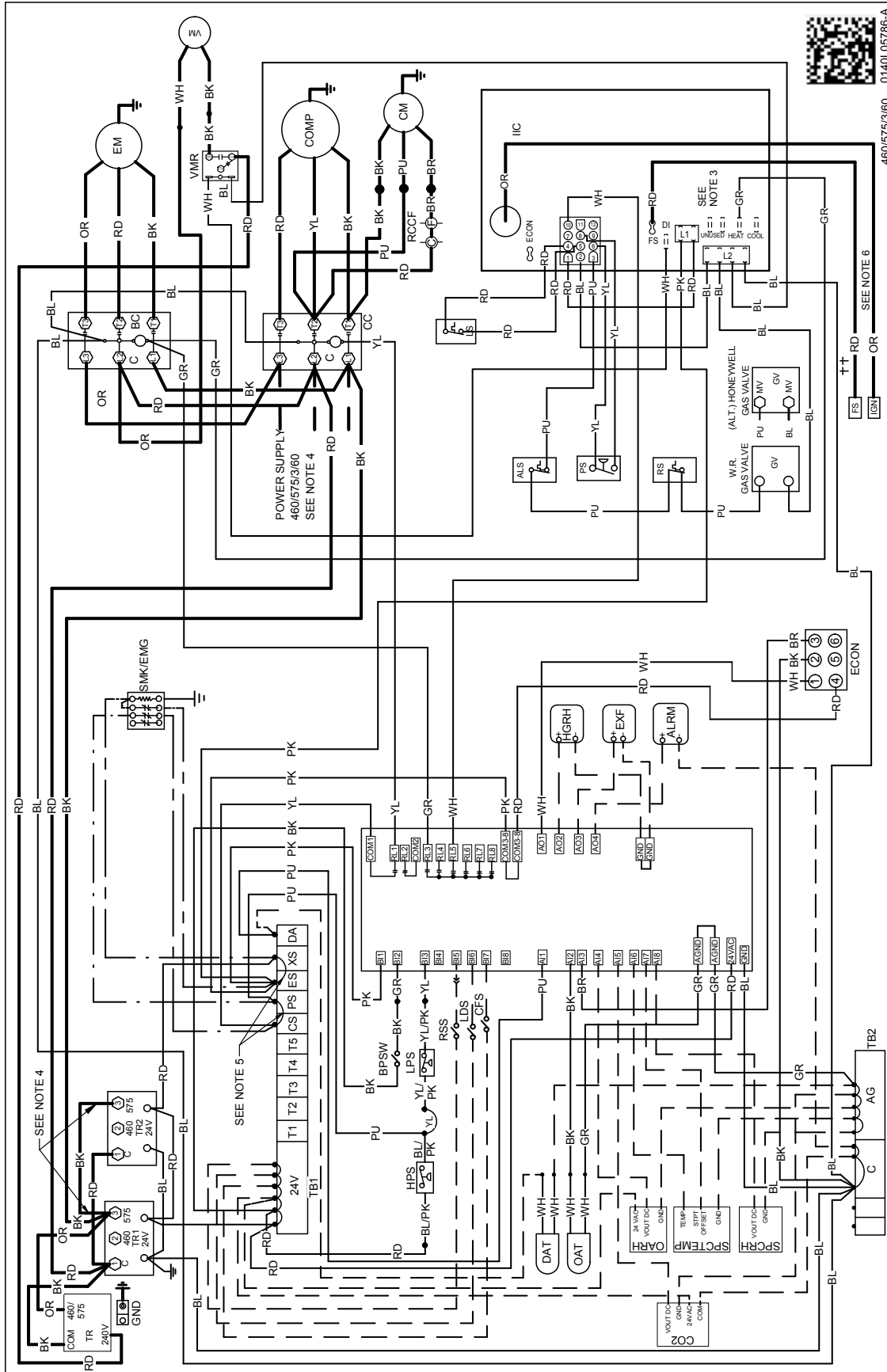

WARNING

High Voltage: Disconnect all power before servicing or installing this unit. Multiple power sources may be present. Failure to do so may cause property damage, personal injury, or death.

Wiring is subject to change. Always refer to the wiring diagram on the unit for the most up-to-date wiring.

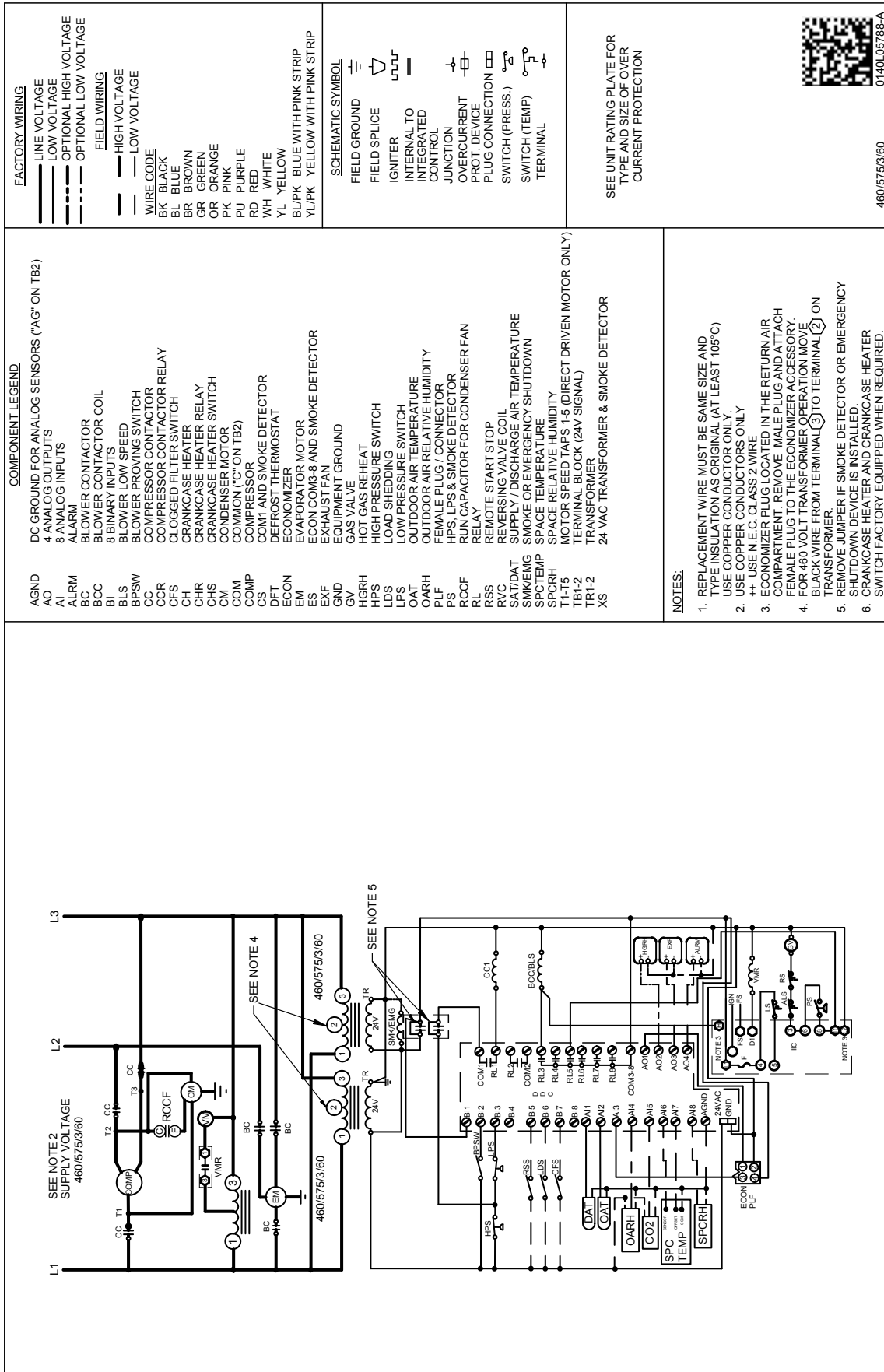

0140L05788-A
 460/575/3/60

WARNING

High Voltage: Disconnect all power before servicing or installing this unit. Multiple power sources may be present. Failure to do so may cause property damage, personal injury, or death.

DAIKIN MASTER ITEM #	DESCRIPTION	FITS MODEL SIZES	FIELD- INSTALLED	FACTORY- INSTALLED	OPERATING WEIGHT (LBS)
14CURB3672	14" Roof Curb	3-6 tons	√		86
D25FD3672	25% Manual Fresh Air Damper	3-6 tons	√		12
D25MFD3672	25% Motorized Fresh Air Damper	3-6 tons	√		16
DDNBBS3672	Burglar Bar Sleeves with Supply & Return	3-6 tons	√		30
CDK36	Concentric Duct Kit	3 tons	√		27
CDK4872	Concentric Duct Kit	4-6 tons	√		27
HAILGD03D	Condenser Coil Hail Guard	3-5 tons	√		19
HAILGD04D	Condenser Coil Hail Guard	6 tons	√		22
	Convenience Outlet: Non Powered	All Models		√	2
	Convenience Outlet: Powered	All Models		√	42
	Disconnect Switch	All Models		√	5
	Ultra Low-Leak Downflow Economizer ¹	3-6 tons		√	71
DDNECNJ3672C	Low-Leak Downflow Economizer ²	3-6 tons	√	√	82
DDNECNJ3672NR	Downflow Economizer ² w/o Barometric Relief	3-6 Tons	√		77
DDNSQRD3616	Downflow Square-to-Round Adapter (16" Round)	3 tons	√		45
DDNSQRD487218	Downflow Square-to-Round Adapter (18" Round)	4-6 tons	√		35
HA-02	High-Altitude Kit	3-6 tons	√		1
HSKT036B ³	High-Static Kit (230/460v)	3 tons	√		41
HSKT036B-7 ³	High-Static Kit (575v)	3 tons	√		5
HSKT048B ³	High-Static Kit (230/460v)	4 tons	√		38
HSKT048B-7 ³	High-Static Kit (575v)	4 tons	√		27
HSKT060B ³	High-Static Kit (230/460v)	5 tons	√		38
HSKT060B-7 ³	High-Static Kit (575v)	5 tons	√		28
HSKT072B ³	High-Static Kit (230/460v)	6 tons	√		38
HSKT072B-7 ³	High-Static Kit (575v)	6 tons	√		15
DHZECNJ3672	Horizontal Economizer	3-6 tons	√		70
GHRC-1	Hurricane Restraint Clips	All Models	√		2
DBRD3672	Barometric Relief Damper	3-6 tons	√		15
LAKT01	Low-Ambient	3-6 tons	√	√	2
LPM-06	LP Conversion Kit	3-6 tons	√		1
LPT-00A	LP Conversion Kit (DCG036045 only)	3 tons	√		1
DPE36722	Downflow Power Exhaust (208/230 Volt)	3-6 tons	√		55
DPE36724	Downflow Power Exhaust (460 Volt)	3-6 tons	√		55
DPE36727	Downflow Power Exhaust (575v)	3-6 tons	√		55
3PMNDK01	Phase Monitor - Non DDC	3-20 tons	√	√	2
	Smoke Detector (supply and/or return air)	All Models		√	11
	Hinged Panels	3-6 tons		√	10
	DDC communicating controller (built-in BACnet® MS/TP)	3-20 tons		√	2
DLAKT01	Low-Ambient*	3-6 tons	√	√	2
LONKT01	LonWorks®*	3-20 tons	√		1
3PMK01	Phase Monitor*	3-20 tons	√	√	2
DFSKT01	Dirty Filter Switch*	3-12½ tons	√		1

¹ Please contact RRS Rooftop Systems directly if Power Exhaust is required. Ultra Low-Leak economizer for DDC controls.

² Please use part number DPE36722 / DPE36724 / DPE36727 if Power Exhaust is required.

³ HSKT High-Static Kits are for use with standard single-speed belt-drive units only.

Note: Where multiple variations are available, the heaviest combination is listed.

*Indicates accessories for use with DDC models only.

